

SPECIFICATIONS:

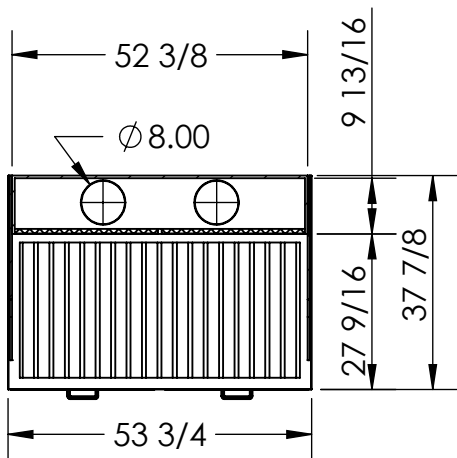

TOP CROSS-SECTIONAL VIEW

CONSTRUCTION:

14 ga. welded steel finished with chemical and oil resistant powder coated paint. Durable construction, able to withstand industrial use. 1 or 2 duct connections 200 mm (8 inch) dia. for connection to remote collection or ventilation operation.

Weight:

492 lbs

NOMINAL CFM:

1770 CFM

Pressure Drop at Nominal Flow:

Without spark arrestor: 1.2 in/wg
With spark arrestor: 1.8 in/wg

Spark Trap TST (set)

Metal wire filter that protects against large particles and reduces the risk of sparking. For mounting in the back panel. Supplied in a set of 2

Weight: 11 lbs/set

Surface Finishing:

Steel parts: Electro-galvanised or powder-coated

Form of Delivery:

The table comes semi-assembled for easy installation

Max Load:

330 lbs

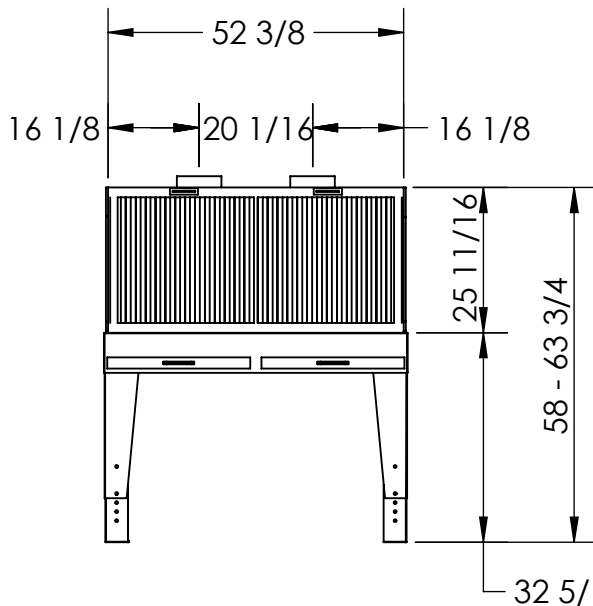

FRONT VIEW

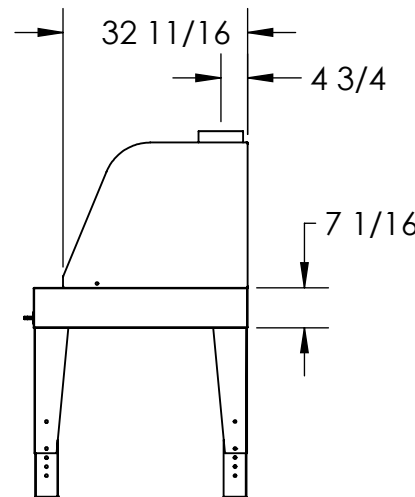

SIDE VIEW

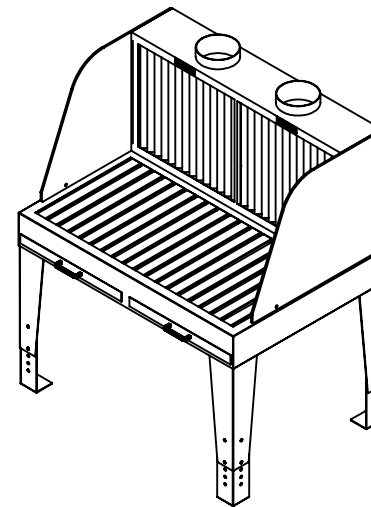

ISOMETRIC VIEW

Notes:

- ALL DIMENSIONS ARE IN INCHES

CUSTOMER:
CUSTOMER PO:
PROJECT:
ENGINEER:
SALES REP:
TAGGING:



The device depicted and described hereon embodies proprietary information owned by the manufacturer. All Design, manufacturing, reproduction, sales and patent rights regarding this device or drawing reserved except where explicit right is guaranteed in writing. We reserve the right to make design changes.

Drawn By: Mark F
Date: 2/3/2021
Scale: NTS
Weight: N/A

(05-12) Lev-co Maxi-Mesa Down-And-Back-Draft Table. 1M and 1.4M

Specification Drawing

Drawing No: - Sheet: 1 / 3
File Name: Maxi-Mesa Spec. Drawing

SPECIFICATIONS:

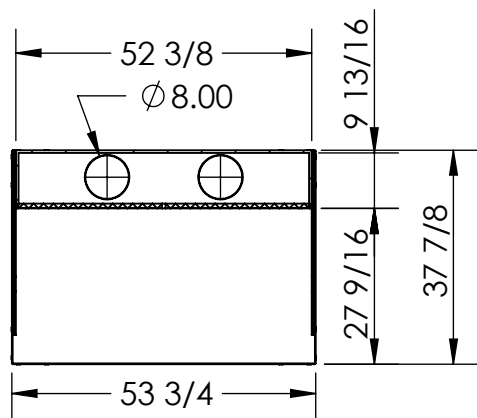

TOP CROSS-SECTIONAL VIEW

CONSTRUCTION: 14 ga. welded steel finished with chemical and oil resistant powder coated paint. Durable construction, able to withstand industrial use. 1 or 2 duct connections 200 mm (8 inch) dia. for connection to remote collection or ventilation operation.:

WEIGHT: 309 lbs

NOMINAL CFM: 1180 CFM

PRESSURE DROP AT NOMINAL FLOW: Without spark arrestor: 1.0 in/wg
With spark arrestor: 1.4 in/wg

MAX LOAD: 330 lbs

SPARK TRAP TST (SET): Metal wire filter that protects against large particles and reduces the risk of sparking. For mounting in the back panel. Supplied in a set of 2

Weight: 11 lbs/set

SURFACE FINISHING Steel parts: Electro-galvanised or powder-coated

FORM OF DELIVERY The table comes semi-assembled for easy installation

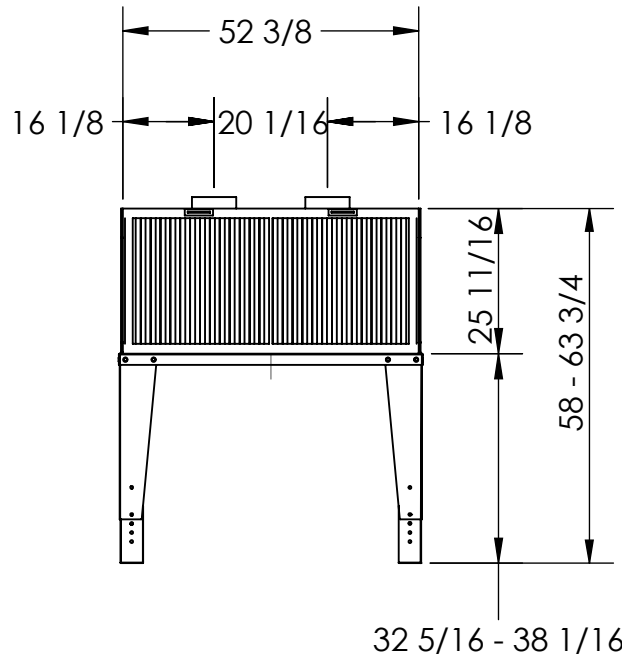

FRONT VIEW

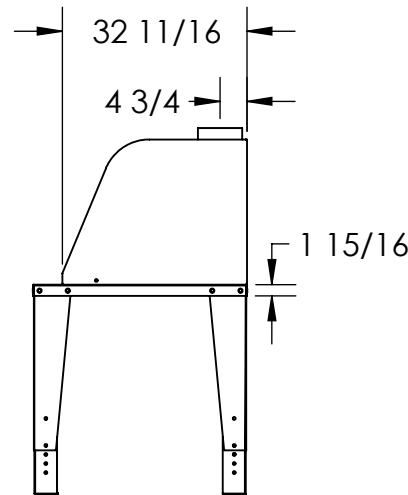

SIDE VIEW

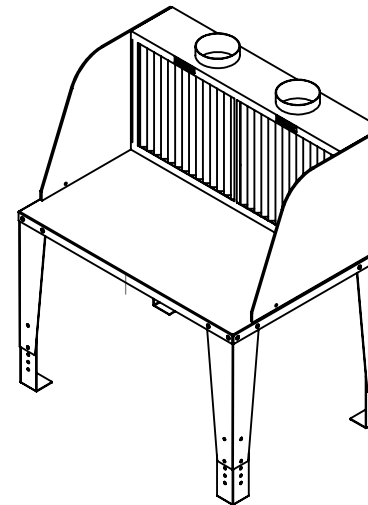

ISOMETRIC VIEW

Notes:

- ALL DIMENSIONS ARE IN INCHES

CUSTOMER:
CUSTOMER PO:
PROJECT:
ENGINEER:
SALES REP:
TAGGING:



The device depicted and described hereon embodies proprietary information owned by the manufacturer. All Design, manufacturing, reproduction, sales and patent rights regarding this device or drawing reserved except where explicit right is guaranteed in writing. We reserve the right to make design changes.

Drawn By: Mark F
Date: 2/2/2021
Scale: NTS
Weight: N/A

(05-12) Lev-co Maxi-Mesa Down-And-Back-Draft Table. 1M and 1.4M

Specification Drawing

Drawing No: - Sheet: 2 / 3
File Name: Super-Mesa Spec. Drawing

MODELS & OPTIONS

Part

Description

Main System/Part

- ___ P-774 Super-Mesa 1m with side panels. 1m x 1m (LxW)
- ___ P-775 Super-Mesa 1.4m with side panels. 1.4m x 1m (LxW)
- ___ P-776 Maxi-Mesa 1m with side panels and 75mm u-formed wide iron bars. 1m x 1m (LxW)
- ___ P-777 Maxi-Mesa 1.4m with side panels and 75mm u-formed wide iron bars. 1.4m x 1m (LxW)
- ___ P-782 Maxi-Mesa 1m with side panels and Vertical 40x5mm flat bar-irons. 1m x 1m (LxW)
- ___ P-783 Maxi-Mesa 1.4m with side panels and Vertical 40x5mm flat bar-irons. 1.4m x 1m (LxW)

Spark Traps

- ___ P-778 Spark Trap for Maxi-Mesa 1m. 2 Pcs.
- ___ P-779 Spark Trap for Maxi-Mesa 1.4m. 2 Pcs.

Flexi Option

- ___ P-069 Flexi FLB 1.5m Extraction Arm. Diameter 160mm.

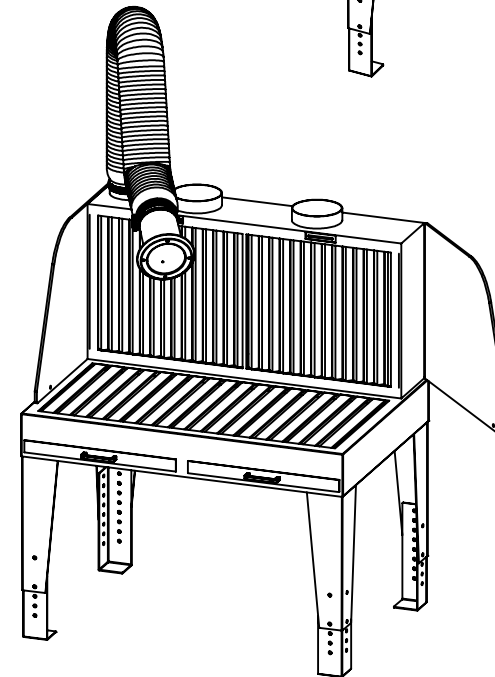
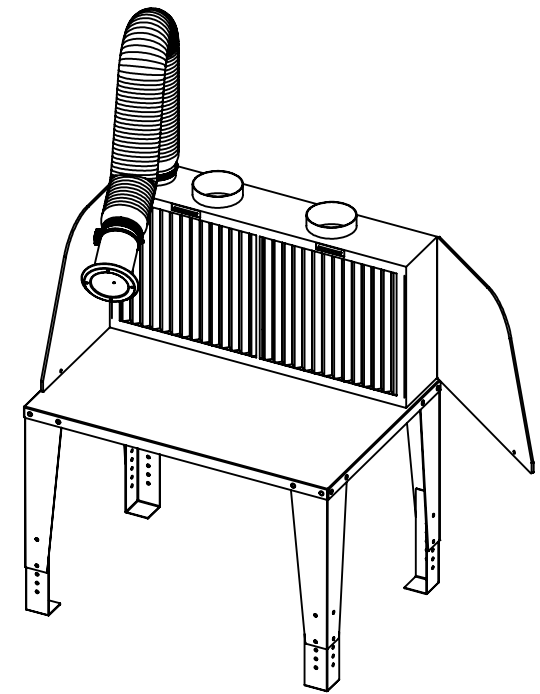

CUSTOMER:	
CUSTOMER PO:	
PROJECT:	
ENGINEER:	
SALES REP:	
TAGGING:	



The device depicted and described hereon embodies proprietary information owned by the manufacturer. All Design, manufacturing, reproduction, sales and patent rights regarding this device or drawing reserved except where explicit right is guaranteed in writing. We reserve the right to make design changes.

Drawn By:	Mark F
Date:	2/3/2021
Scale:	NTS
Weight:	N/A

(05-12) Lev-co Maxi-Mesa Down-And-Back-Draft Table. 1M and 1.4M	
Specification Drawing	
Drawing No: -	Sheet: 2 / 3
File Name: Maxi-Mesa Spec. Drawing	