

CUSTOMER:
CUSTOMER PO:
PROJECT:
PROJECT NAME:
TAG:

H-MAX-EZ
Articulating Extension Boom
for E-Z Arm c/w 8" ϕ duct kit or hose

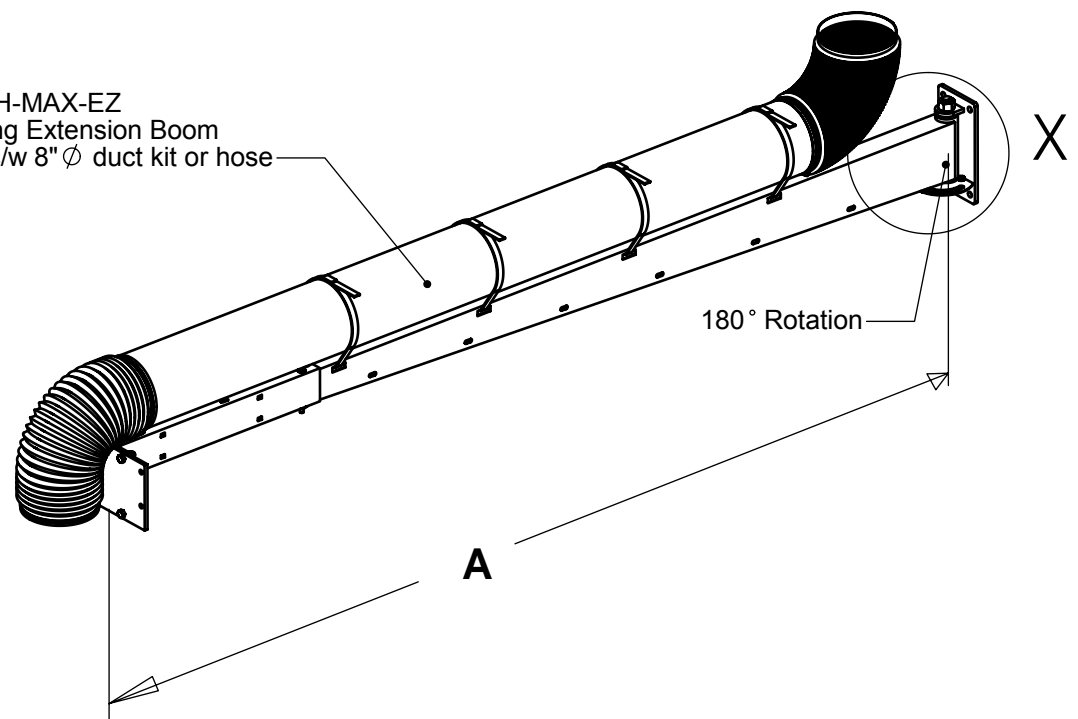

Detail X

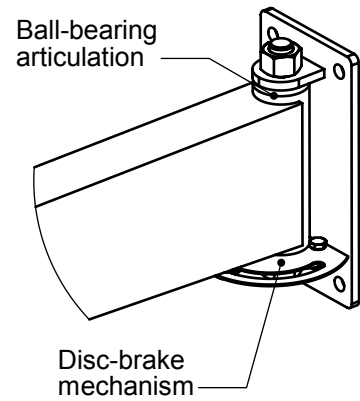

Wall Mounting Flange

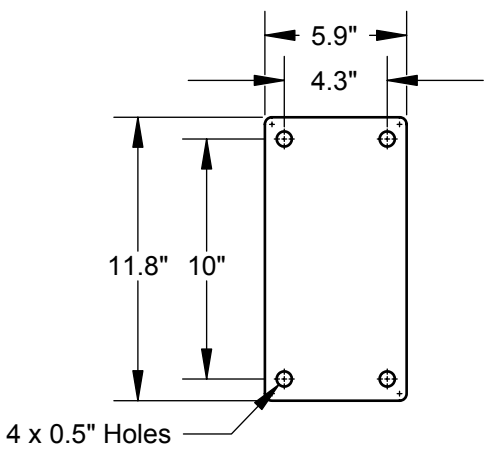

H-MAX	A
H-MAX-EZ-1	2m (7')
H-MAX-EZ-2	3m (10')
H-MAX-EZ-3	4m (13')
H-MAX-EZ-1/D	2m (7')
H-MAX-EZ-2/D	3m (10')
H-MAX-EZ-3/D	4m (13')

- H-MAX-EZ-1: 2m (6.5') H-MAX Boom Kit for E-Z Arms c/w hose
- H-MAX-EZ-2: 3m (10') H-MAX Boom Kit for E-Z Arms c/w hose
- H-MAX-EZ-3: 4m (13') H-MAX Boom Kit for E-Z Arms c/w hose
- H-MAX-EZ-1/D: 2m (6.5') H-MAX Boom Kit for E-Z Arms c/w duct kit
- H-MAX-EZ-2/D: 3m (10') H-MAX Boom Kit for E-Z Arms c/w duct kit
- H-MAX-EZ-3/D: 4m (13') H-MAX Boom Kit for E-Z Arms c/w duct kit

lev-co	THE LOCAL EXHAUST & VENTILATION COMPANY	
	www.LEV-CO.com	
Sales@LEV-CO.com		
North America: Phone: 888.862.5356, Fax: 8668409923		
The device depicted and described hereon embodies proprietary information owned by the manufacturer. All design, manufacturing, reproduction, sales and patent rights regarding this device or drawing reserved except where explicit right is guaranteed in writing. We reserve the right to make design changes.	Drawn by: Adrian Pop	Title:
	Date: 11/04/2006	H-MAX-EZ Articulating Extension Boom for E-Z Arm c/w 8" ϕ duct kit or hose Specification Drawing
	Scale: NTS	
	Weight: 00.0	Drawing No.: S-32564-00
		Material: -
		Sheet 1/1