

SPECIFICATIONS:

CONSTRUCTION: 12/14/16 Gauge steel cabinet finished with Powder-Coat Finish. Includes a 10 gallon external dust drawer, removable end cap for easy access to filters, removable panel for easy access to direct drive motor/blower, 25' 12 Ga. power cord, and on-off switch. Motor wired to junction box outside of unit for 3 phase option. Acoustical lining standard in blower compartment. Vibra-Pulse cleaning standard. 10 ft FLEXI-II Extractor arm - Standard

MAIN FILTERS:

- (2) CLEAN-2 Filter cartridge, 16"Dx12", Std.
- (2) Cartridge, FIBERDUST, Opt.
- (2) Cartridge, Spark Resistant, Opt.
- (2) Cartridge, Spunbond - HO, Opt.
- (2) Cartridge, CleanPlus double treated fire retardant, Opt.

WEIGHT: 260 lbs.
AIRFLOW: 1000 CFM with std. 1.5 HP motor
 1200 CFM with opt. 3 HP motor
 1500 CFM with opt. 5 HP motor

HEPA OPTIONS: (1) External HEPA filter, 99.97%

AD OPTION: (1) External adsorber, 25 lb. capacity

NOISE: 77 dBA - 1.5 HP
 79 dBA - 3 HP
 81 dBA - 5 HP

OTHER OPTIONS:

- Pressure gauge kit indicates filter changes
- Hopper option
- Auto Clean, (w/Hopper opt.)
- Regulator
- 14 Ft. E-Z Arm
- Silencer (Adds 3" to depth of unit)

ELECTRICAL:

- 1.5 HP 115/220/1/60, 15/7.9-7.5 amps, std
- 1.5 HP 230/460/3/60, 4.9-4.6/2.3 amps, opt.
- 3 HP 208-230/460/3/60, 8.4-8.0/4.0 amps, opt.
- 5 HP 208-230/3/60, opt.

FIRE SUPPRESSION: Equipment provided by others.

SPECIAL NOTES: Compressed air filter provided by others.

FILTER EFFICIENCIES BASED ON ASHRAE 52-76 TEST METHOD

PERFORMANCE CURVES

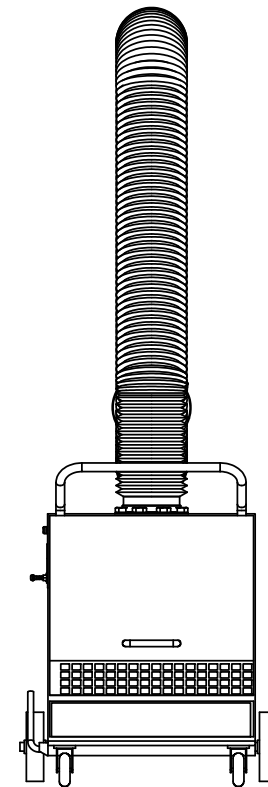
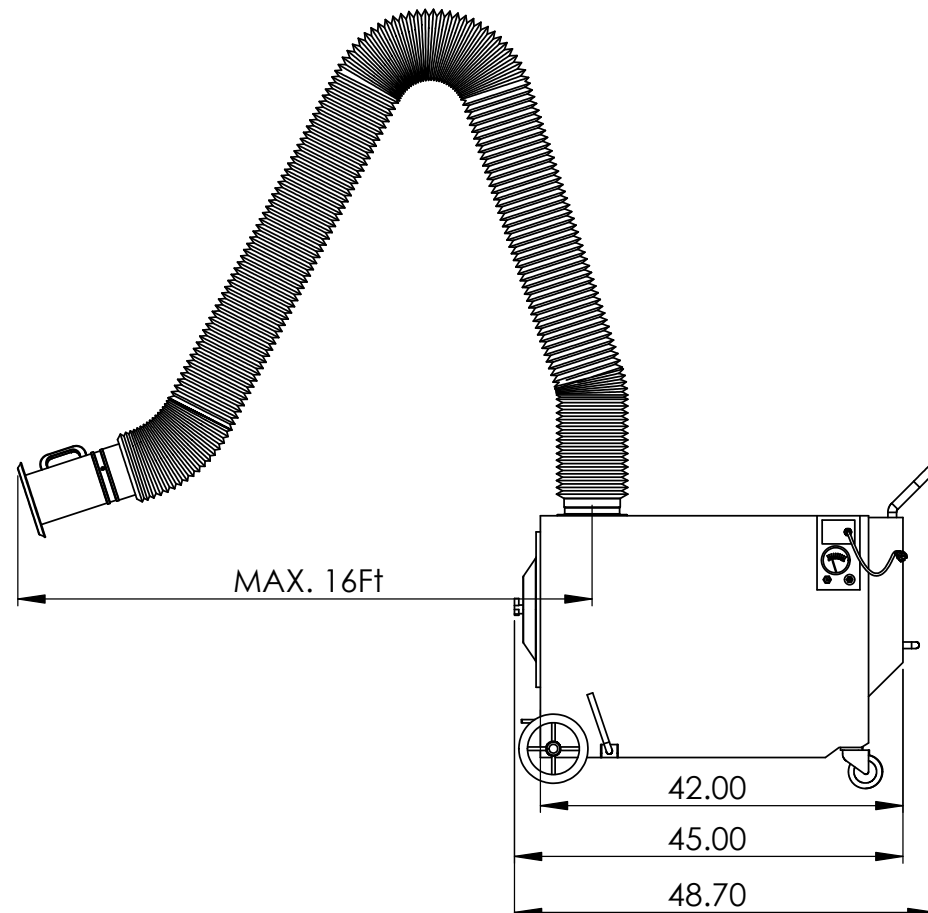
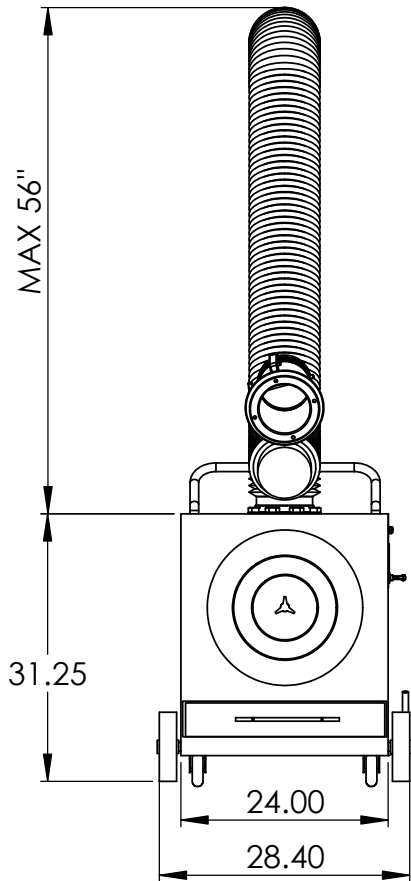
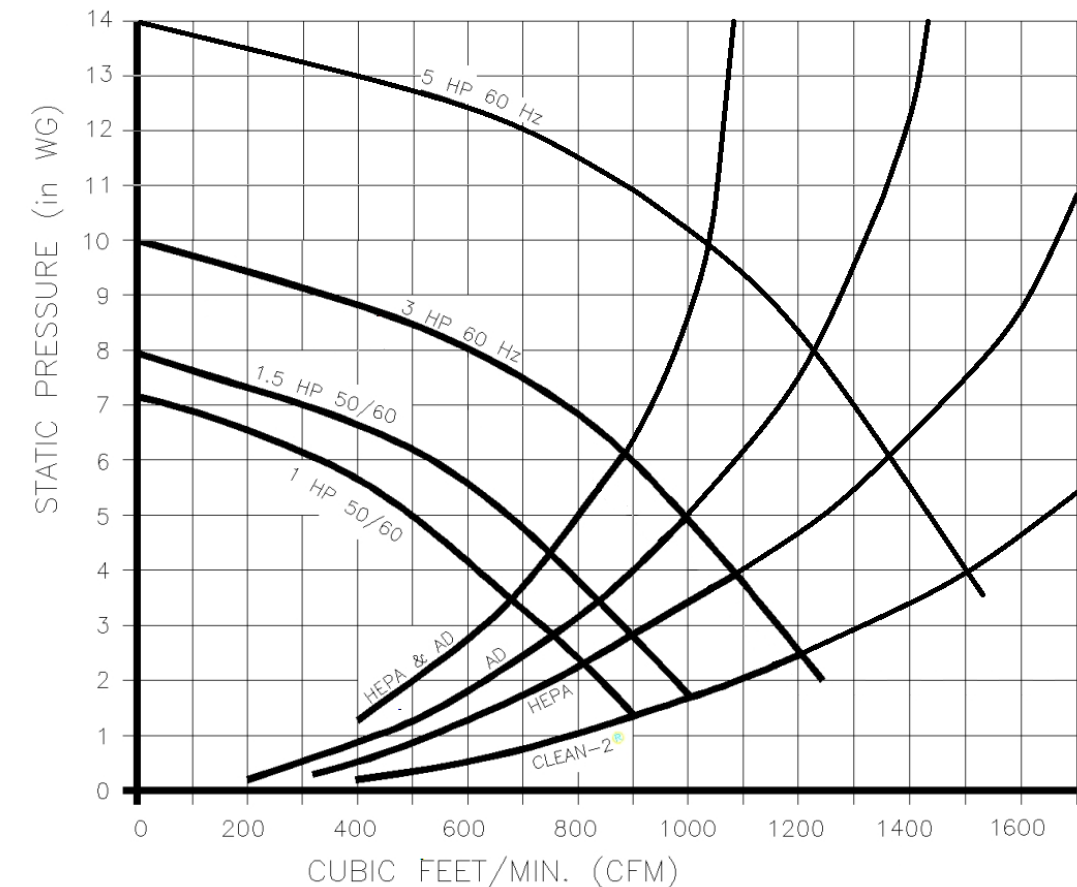

CUSTOMER:
 CUSTOMER P.O.:
 PROJECT:
 ENGINEER:
 SALES REP.:
 IDENTIFICATION / TAGGING:

> www.lev-co.com • 1.888.862.5356

lev-co

The device depicted and described hereon embodies proprietary information owned by the manufacturer. All design, manufacturing, reproduction, sales and patent rights regarding this device or drawing reserved except where explicit right is guaranteed in writing. We reserve the right to make design changes.

Drawn by: Janos B
 Date: 6/27/2014
 Scale: NTS
 Weight: N/A

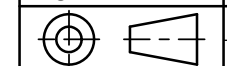

MOBI-PULSE 2
Portable Dust Collector
 Specification Drawing

Drawing No.: -
 Material: -
 File Name: Mobi-Pulse 2 - SD
 Sheet: 1/5

EXTRA-LARGE REACH OPTION

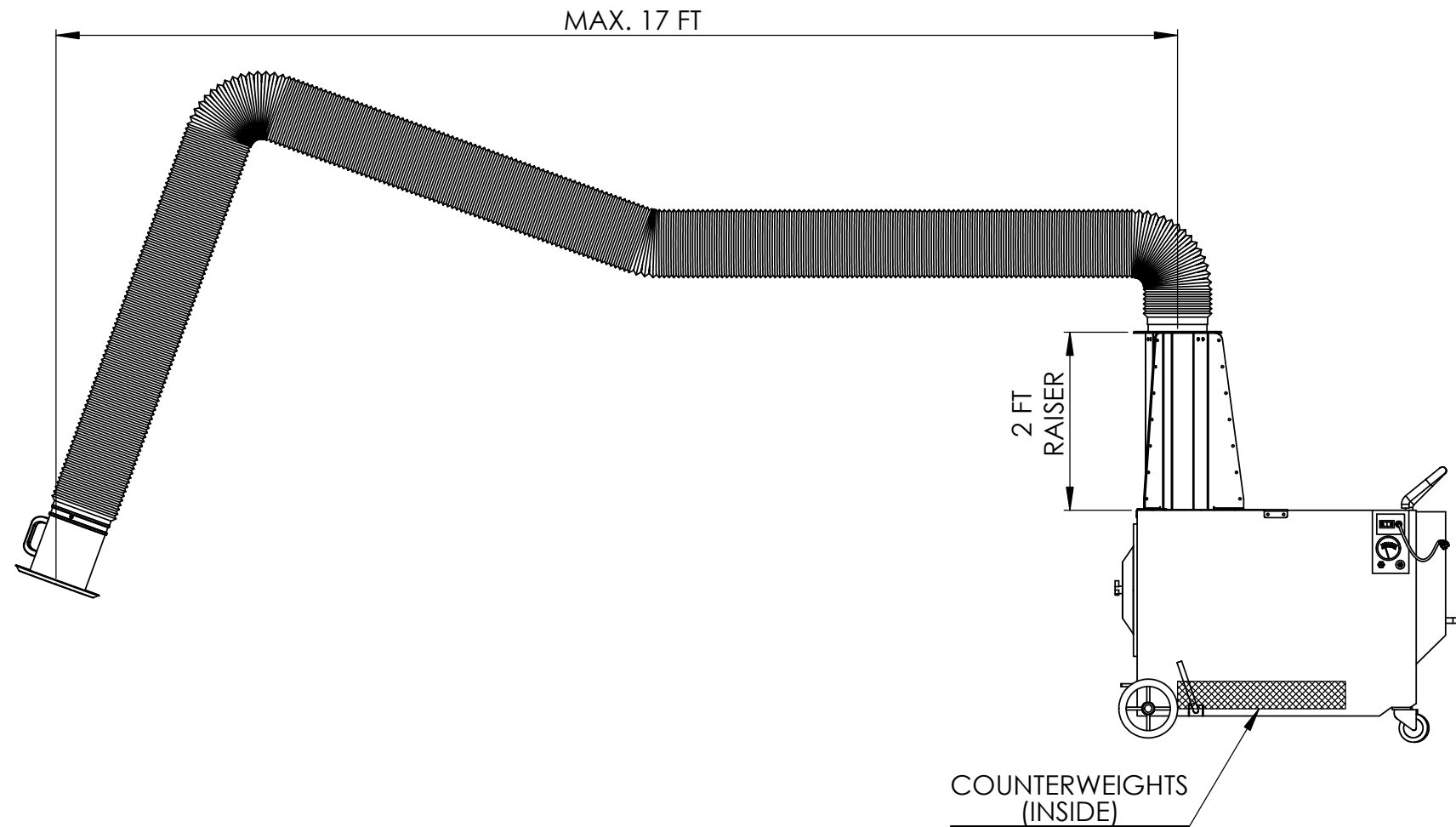
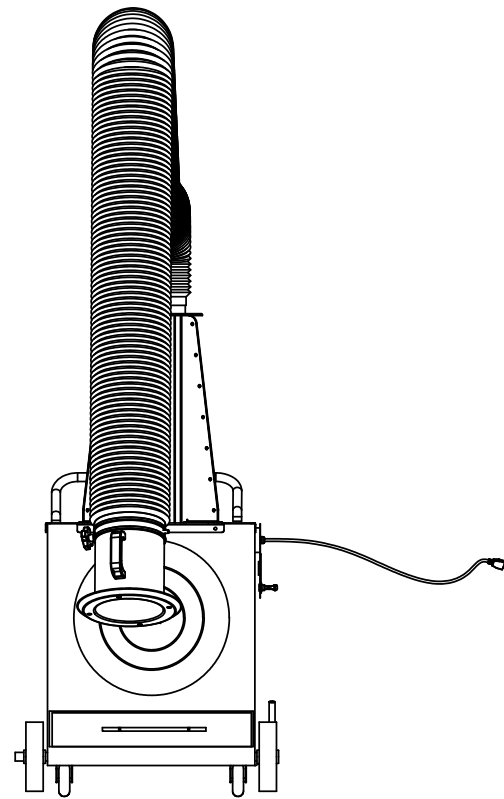
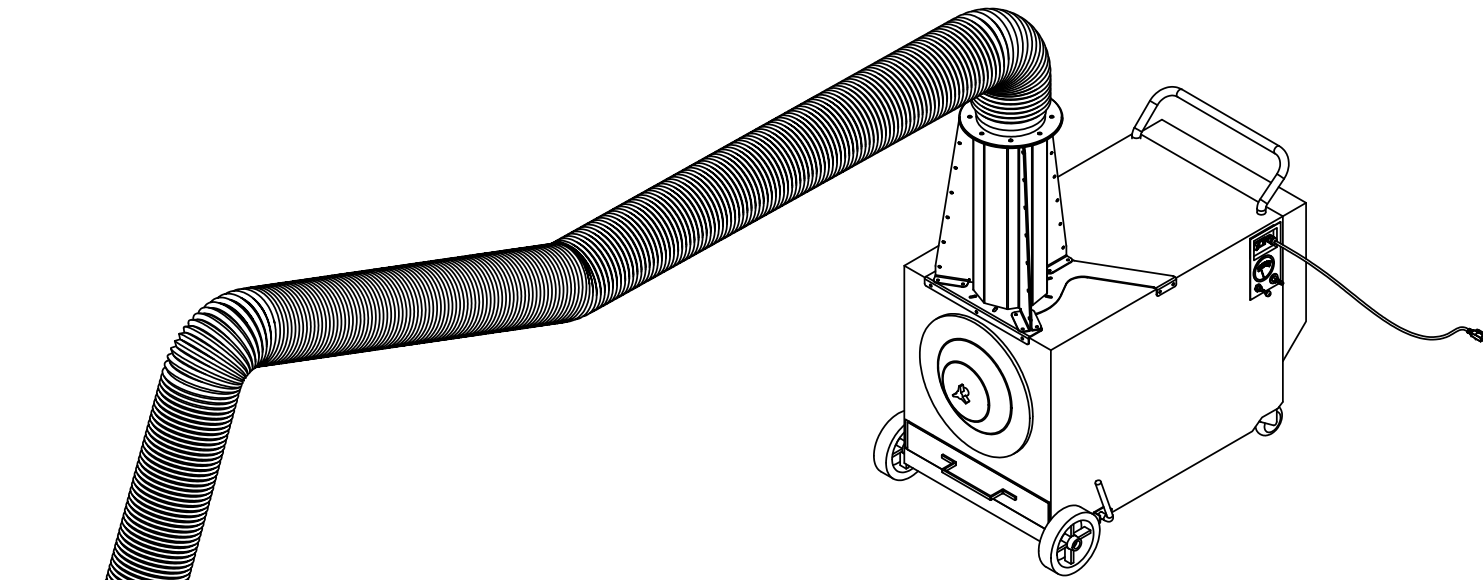

CUSTOMER:
 CUSTOMER P.O.:
 PROJECT:
 ENGINEER:
 SALES REP.:
 IDENTIFICATION / TAGGING:

> www.lev-co.com • 1.888.862.5356

lev-co

The device depicted and described hereon embodies proprietary information owned by the manufacturer. All design, manufacturing, reproduction, sales and patent rights regarding this device or drawing reserved except where explicit right is guaranteed in writing. We reserve the right to make design changes.

Drawn by: Janos B
 Date: 6/27/2014
 Scale: NTS
 Weight: N/A

MOBI-PULSE 2
Portable Dust Collector
 Specification Drawing

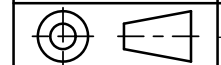

Drawing No.: -
 Material: -
 File Name: Mobi-Pulse 2 - SD
 Sheet: 2/5

DUAL ARMS OPTION

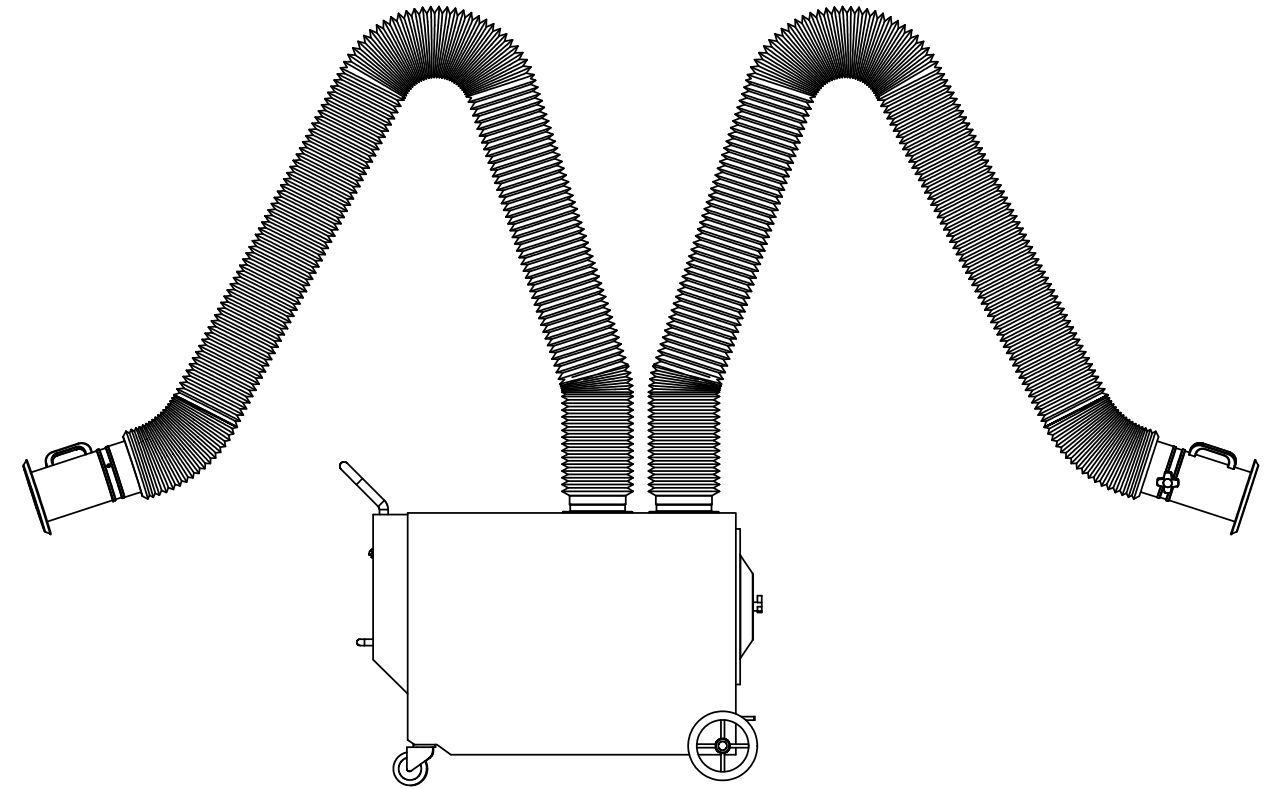
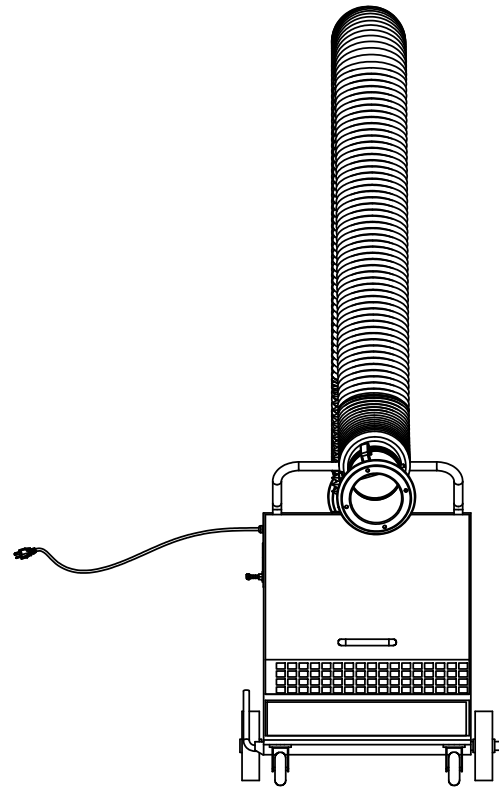
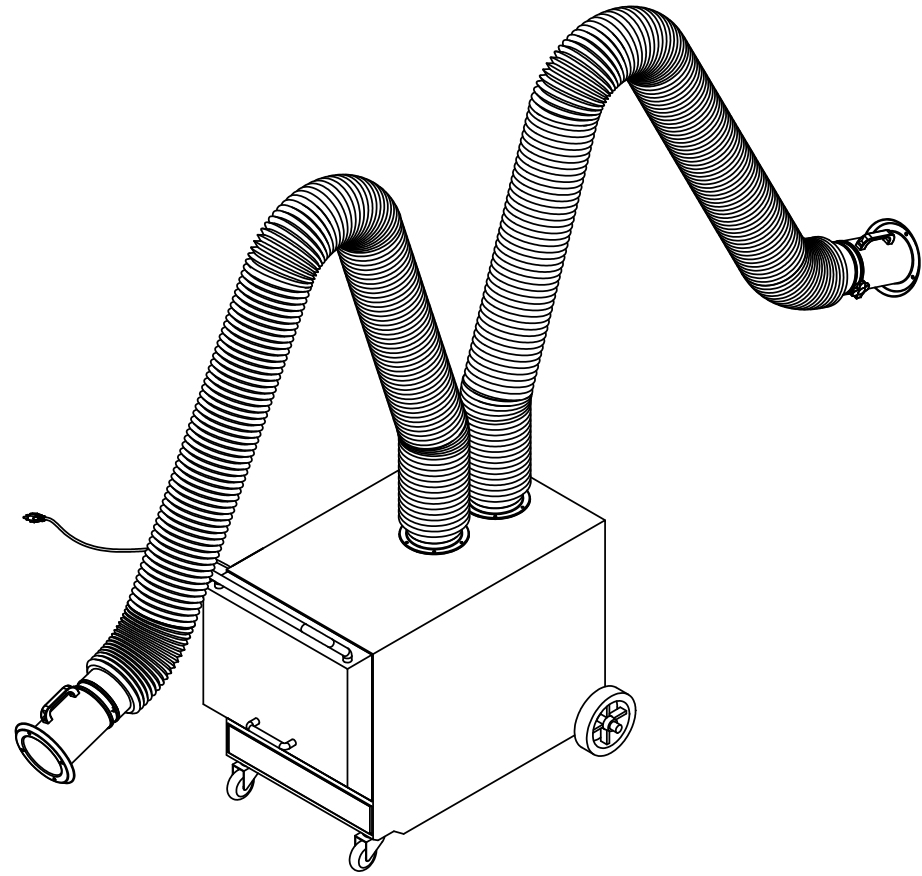

CUSTOMER:
CUSTOMER P.O.:
PROJECT:
ENGINEER:
SALES REP.:
IDENTIFICATION / TAGGING:

www.lev-co.com • 1.888.862.5356



The device depicted and described hereon embodies proprietary information owned by the manufacturer. All design, manufacturing, reproduction, sales and patent rights regarding this device or drawing reserved except where explicit right is guaranteed in writing. We reserve the right to make design changes.

Drawn by:	Janos B
Date:	6/27/2014
Scale:	NTS
Weight:	N/A

MOBI-PULSE 2	
Portable Dust Collector	
Specification Drawing	
Drawing No.: -	File Name: Mobi-Pulse 2 - SD
Material: -	Sheet: 3/5

MODELS & OPTIONS:

Main System / Part	Part #	Description
<input type="checkbox"/>	MPLS1-160-2M	Mobi-Pulse-1 Filtration unit c/w (1) only 7' Flexi-I Extraction arm (6.5 dia.) with damper, Pulse filter cleaning system, a 1 HP 115/1/60 TEFC motor, centrifugal blower, removable 5 gallon dust drawer, 5" front (fixed) & rear (swivel) casters. AS PER CANADIAN LAW; this unit is approved by CSA field evaluation prior to shipping in order to meet Canadian Laws and for your additional safety
<input type="checkbox"/>	MPLS1-160-3M	Mobi-Pulse-1 Filtration unit c/w (1) only 10' Flexi-I Extraction arm (6.5 dia.) with damper, Pulse filter cleaning system, a 1.5 HP 115/1/60 TEFC motor, centrifugal blower, removable 5 gallon dust drawer, 5" front (fixed) & rear (swivel) casters. AS PER CANADIAN LAW; this unit is approved by CSA field evaluation prior to shipping in order to meet Canadian Laws and for your additional safety
<input type="checkbox"/>	MPLS2-200-2M	Mobi-Pulse 2 Filtration unit c/w (1) only 2M (7')Flexi-II Extraction arm (8 dia.) with damper, (2) filter cartridges (150ft² of media each), manual VIBRA-PULSE filter cleaning system, a 1.5 Hp 115/1/60Hz TEFC motor, centrifugal blower, removable 5 gallon dust drawer, 8" front (fixed) & 5 rear (swivel) casters. AS PER CANADIAN LAW; this unit is approved by CSA field evaluation prior to shipping in order to meet Canadian Laws and for your additional safety
<input type="checkbox"/>	MPLS2-200-3M	Mobi-Pulse 2 Filtration unit c/w (1) only 3M (10')Flexi-II Extraction arm (8 dia.) with damper, (2) filter cartridges (300ft² of media each), manual VIBRA-PULSE filter cleaning system, a 1.5 Hp 115/1/60Hz TEFC motor, centrifugal blower, removable 5 gallon dust drawer, 8" front (fixed) & 5"rear (swivel) casters. AS PER CANADIAN LAW; this unit is approved by CSA field evaluation prior to shipping in order to meet Canadian Laws and for your additional safety
<input type="checkbox"/>	MPLS2-200-4M	Mobi-Pulse 2 Filtration unit c/w (1) only 4M (14')Flexi-II Extraction arm (8 dia.) with damper, (2) filter cartridges (300ft² of media each), manual VIBRA-PULSE filter cleaning system, a 3 Hp 115/1/60Hz TEFC motor, centrifugal blower, removable 5 gallon dust drawer, 8" front (fixed) & 5"rear (swivel) casters. AS PER CANADIAN LAW; this unit is approved by CSA field evaluation prior to shipping in order to meet Canadian Laws and for your additional safety
<input type="checkbox"/>	MPLS2-200-5M	Mobi-Pulse 2 Filtration unit c/w (1) only 5M (17')Flexi-II Extraction arm (8 dia.) with damper, (2) filter cartridges (300 ft media each), manual VIBRA-PULSE filter cleaning system, a 5 Hp 115/1/60Hz TEFC motor, centrifugal blower, removable 5 gallon dust drawer, 8" front (fixed) & 5"rear (swivel) casters. AS PER CANADIAN LAW; this unit is approved by CSA field evaluation prior to shipping in order to meet Canadian Laws and for your additional safety

Fan / Motor Upgrades or Options (when ordering main unit)	Part #	Description
<input type="checkbox"/>	DCH-2-3HP	3 Hp TEFC motor, 575/3/60 Hz, High Flow Option for Standard DCH-2 Unit
<input type="checkbox"/>	DCH-2-5HP	5 Hp TEFC motor, 575/3/60Hz, High Flow Option for Standard DCH-2 Unit
<input type="checkbox"/>	PCH-2-3HP	3 Hp 3 Phase, TEFC, 208-230/460/575/3/60 Hz, High Pressure Option for Standard PCH-2 Unit

Filter Options (when ordering main unit)	Part #	Description
<input type="checkbox"/>	PCH-2-EXAD	External AD Module Option for Standard PCH-2 Unit
<input type="checkbox"/>	PCH-2-EXHE	External 99.97% HEPA Filter Option for Standard PCH-2 Unit

Hose, Hood & Nozzle Options	Part #	Description
<input type="checkbox"/>	HS-2500-160	2500 °F Hose Shield for all 6 & 6.5Ø hoses. 30" in length

Silencer Option (when ordering main unit)	Part #	Description
<input type="checkbox"/>	DCH-2-S-EXT	External Silencer Option for Standard DCH-2 Unit

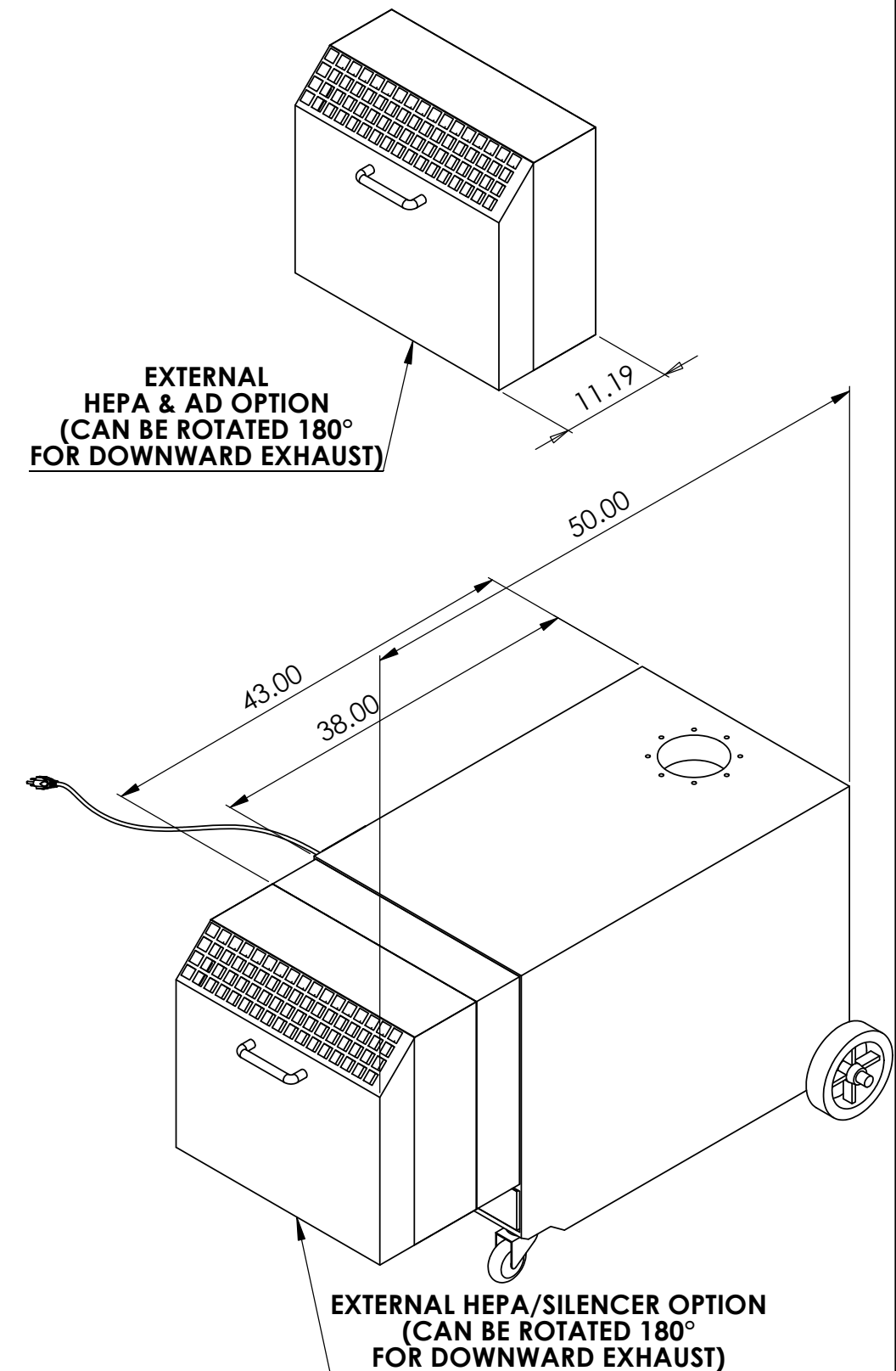

CUSTOMER:
CUSTOMER P.O.:
PROJECT:
ENGINEER:
SALES REP.:
IDENTIFICATION / TAGGING:

www.lev-co.com • 1.888.862.5356



The device depicted and described hereon embodies proprietary information owned by the manufacturer. All design, manufacturing, reproduction, sales and patent rights regarding this device or drawing reserved except where explicit right is guaranteed in writing. We reserve the right to make design changes.

Drawn by:	Janos B
Date:	6/27/2014
Scale:	NTS
Weight:	N/A

MOBI-PULSE 2	
Portable Dust Collector	
Specification Drawing	
Drawing No.:	-
Material:	-
File Name:	Mobi-Pulse 2 - SD
Sheet:	4/5

MODELS & OPTIONS:

Misc. Options

Misc. Options	Part #	Description
<input type="checkbox"/>	DCH-2-EXAD	External Adsorber Module Option for Standard DCH-2 Unit

Filter Options

Filter Options	Part #	Description
<input type="checkbox"/>	DCH-2-EXHE	External 99.97% HEPA Filter Option for Standard DCH-2 Unit

Preventative Maintenance Pressure Gauges, etc. (when ordering main unit)

Preventative Maintenance Pressure Gauges, etc. (when ordering main unit)	Part #	Description
<input type="checkbox"/>	DCH-2-PG-10	0-10 magna-helic pressure gauge, approximately 5 diameter size. Surface mounted.
<input type="checkbox"/>	PCH-2-PG-6	0-6 magna-helic pressure gauge, approximately 5 diameter size. Surface mounted.

Replacement filters - (Quantity discounts available upon request)

Replacement filters - (Quantity discounts available upon request)	Part #	Description
<input type="checkbox"/>	7FJ9-9003	99.97% @ 0.3 microns HEPA Filter for PCH/DCH/DTH/ALH units, Metal Frame
<input type="checkbox"/>	7FJ9-9003-W	99.97% @ 0.3 microns HEPA Filter for PCH/DCH/DTH/ALH units WOOD FRAME
<input type="checkbox"/>	7FRO-2020	Flame Retardant Cartridge Filter made of 80/20% Cell/Poly Blend., Replacement Filter for DCH/PCH/DTH, TC-4, HC-4, DC-4/6/8/12/18 & DT-3000V2 filter units. Complete with Vibra Pulse Tube
<input type="checkbox"/>	7FRO-2020-BB	FR Cellulose Polyester Blend Cartridge for DCH-2, PCH-2 DT-1700 C/W 2 Vibra-Pulse tubes.
<input type="checkbox"/>	7FRO-2020-OEM	Cartridge for PCH-1, PCH-2, DCH-1, DCH-2, DC-4, DC-6, DC-8, DC-12, TC-4, HC-4, DT3000v2.0, DTH-800 and DTH-1700. Cartridge, CLEAN-2 ®, 150 sq.ft. of media. Open both ends. C/W Vibra-Pulse tube.
<input type="checkbox"/>	7FRO-2027	Teflon Filter for DCH/PCH/DTH, TC-4, HC-4, DC-4/6/8/12/18 & DT-3000V2 filter units. VIBRA-PULSE tubes included
<input type="checkbox"/>	7FRO-2027-OEM	Cartridge filter for DC-8, DT3000v2.0, DC-4, DC-6, DC-12, TC-4 and HC-4 Complete with Vibra pulse tubes.
<input type="checkbox"/>	7FRO-5020	OEM Cartridge Filter ALH-1/2/6 filter used in explosive and flammable applications such as aluminum dust applications.
<input type="checkbox"/>	Charcoal-CP40	40" lb of CP Blend of chemisorbant and activated carbon blend. Target Contaminants: Hydrocarbons VOC's Oxides of sulfur Formaldehyde Nitric Oxide Hydrogen Sulfide Lower molecular weight aldehydes and organic acids

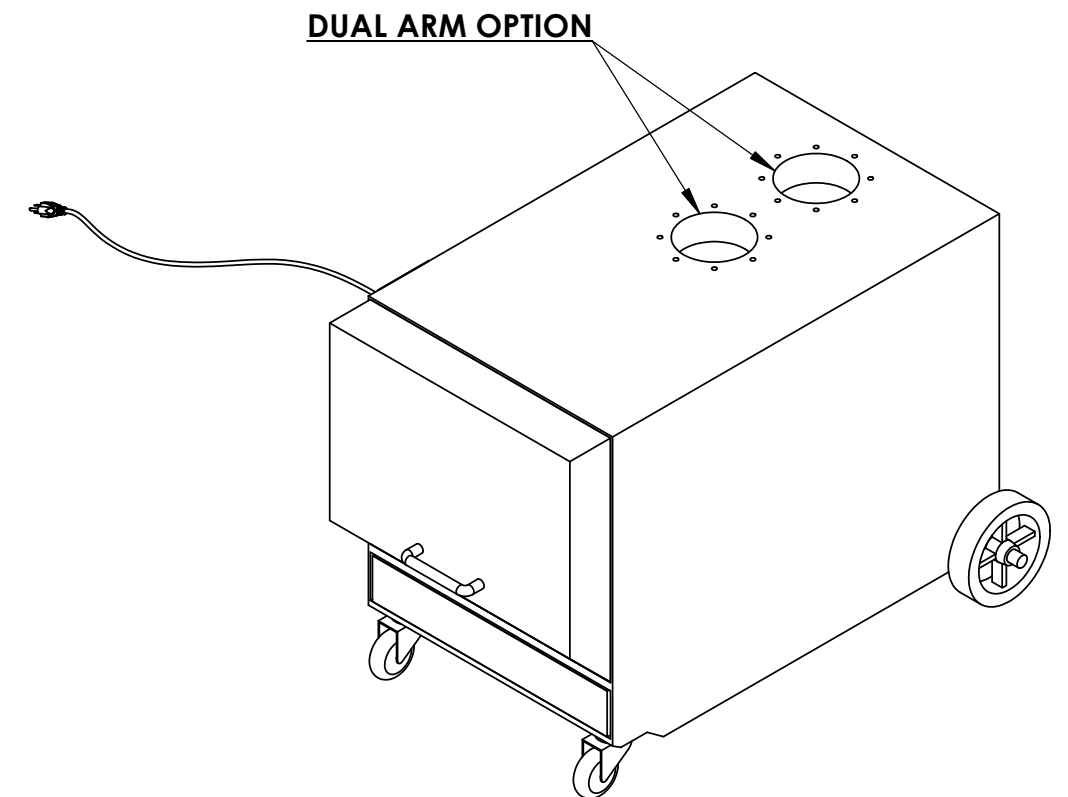
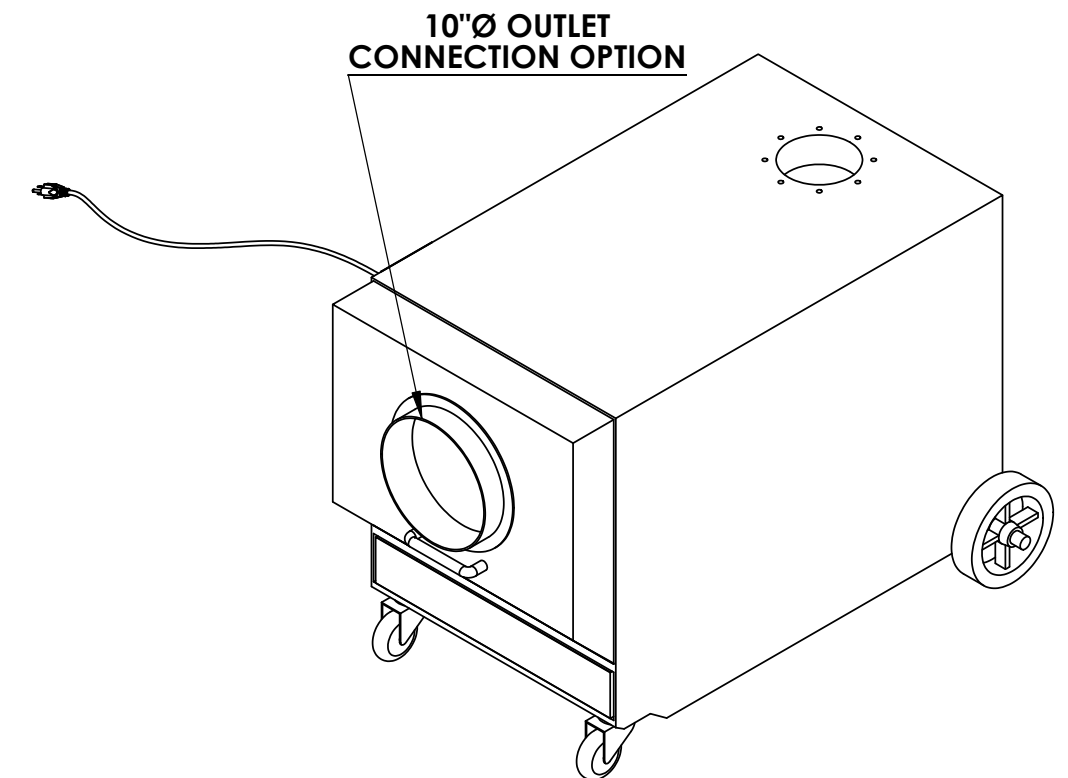

CUSTOMER:
CUSTOMER P.O.:
PROJECT:
ENGINEER:
SALES REP.:
IDENTIFICATION / TAGGING:

> www.lev-co.com • 1.888.862.5356

lev-co

The device depicted and described hereon embodies proprietary information owned by the manufacturer. All design, manufacturing, reproduction, sales and patent rights regarding this device or drawing reserved except where explicit right is guaranteed in writing. We reserve the right to make design changes.

Drawn by: Janos B
Date: 6/27/2014
Scale: NTS
Weight: N/A

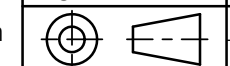

MOBI-PULSE 2
Portable Dust Collector
Specification Drawing

Drawing No.: -
Material: -
File Name: Mobi-Pulse 2 - SD
Sheet: 5/5