

TOP VIEW

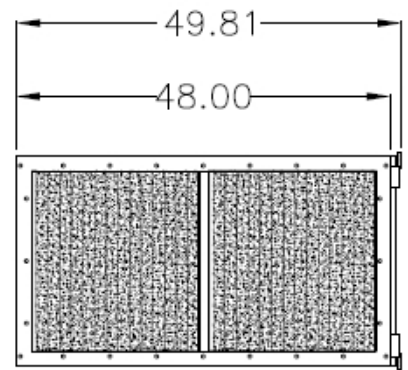

OUTLET VIEW

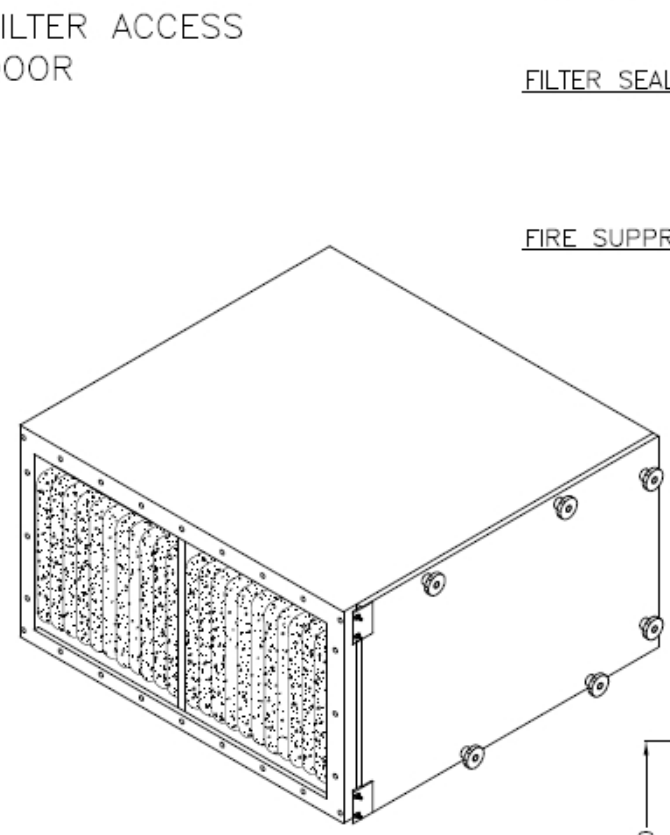

SIDE VIEW

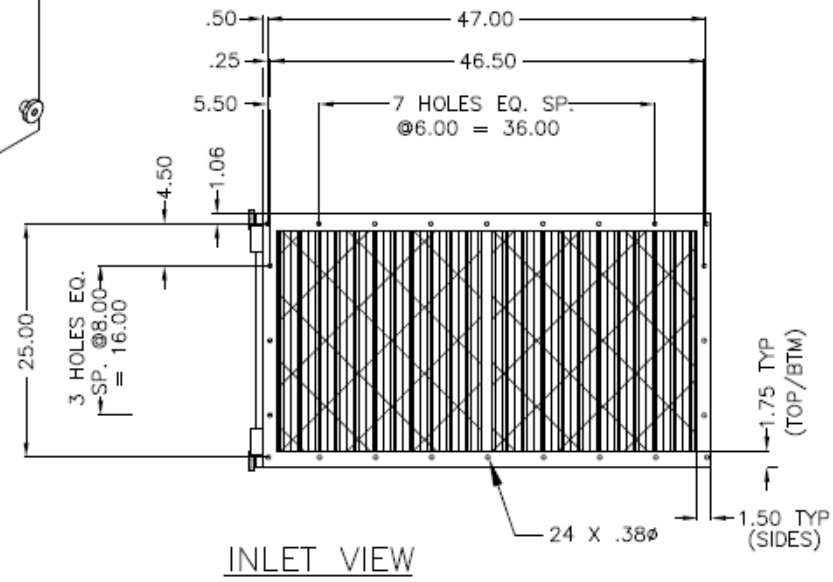

INLET VIEW

SPECIFICATIONS:

CONSTRUCTION: 16 Gauge welded zinc coated steel cabinet, finished with a two part chemical and oil resistant paint, with Ultra-Seal filter mounting system, and a hinged side access door to filters. Blowerless.

WEIGHT: 225 lbs.

AIRFLOW: 8000 CFM
4000 CFM W/HEPA

FILTER SEAL: Ultra-Seal, welded picture frame with positive sealing filter locking mechanism for all main filters and all HEPA filters or adsorber modules (when used). Slide in tracks shall be used for prefilters only

FIRE SUPPRESSION: Equipment provided by others.

- PREFILTERS:**
- (2) 4" Pleated std.
 - (2) Aluminum Mesh, opt.
 - (2) Chevron Filter, opt.
 - (2) OM impingement, opt.
 - (1) Auto Roll, opt.
- MAIN FILTERS:**
- (2) 120 ft² multi-pocket 95%, std.
 - (2) 65% - opt.
 - (2) Easy clean, opt.
- AFTER FILTERS:**
- (2) HEPA filters, 99.97% preceded by (2) 66 ft² 95% bag filters, and (2) 4" pleats, opt.
 - (2) 95% D.O.P. HEPA, opt.
- AD OPTION:**
- (4) 25 lb. refillable adsorber modules, with (2) 66 ft², 95% multi-pocket filters, and (2) 2" pleat final filters, opt.
- OTHER OPTIONS:**
- Pressure gauge kit indicates filter changes
 - Source capture plenum/Outlet plenum
 - 3/4" NPT Drain

* AFS FILTER EFFICIENCIES BASED ON ASHRAE 52-76 TEST METHOD

PERFORMANCE CURVES

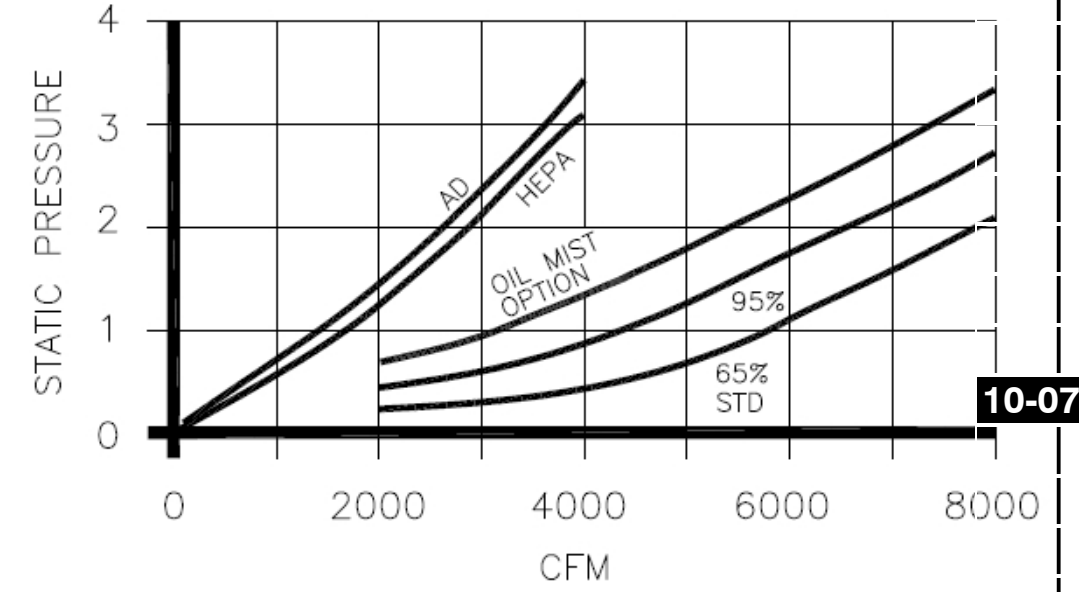

CUSTOMER:	
CUSTOMER P.O.:	
PROJECT:	
ENGINEER:	
SALES REP.:	
IDENTIFICATION / TAGGING:	

www.lev-co.com • 1.888.862.5356



The device depicted and described hereon embodies proprietary information owned by the manufacturer. All design, manufacturing, reproduction, sales and patent rights regarding this device or drawing reserved except where explicit right is guaranteed in writing. We reserve the right to make design changes.

Drawn by:	JANOS-B
Date:	5/1/2008
Scale:	NTS
Weight:	N/A

10-07 202	
Filter Pack	
Specification Drawing	
Drawing No.:	File Name: (10-07) 203 Filter Pack - SD
Material:	Product manufactured by: Airflow SYSTEMS INC.
	Sheet: 1/2

MODELS & OPTIONS

Part # Description

Main System / Part

202 Modular air cleaner, blower less. Includes (2) 4" pleated 30% prefilters, (2) 95% main filters, 120 sq. ft.

Filter Options (when ordering main unit)

- 202-95DOP 95% DOP HEPA Filter Option for Standard 202 Unit
- 202-AD AD Module Option for Standard 202 Unit. Order Charcoal separately.
- 202-AR Auto-Roll Prefilter Option for Standard 202 Unit
- 202-CV Chevron Filter Option for Standard 202 Unit
- 202-EC Easy Clean Bag Filter Option for Standard 202 Unit
- 202-HEPA 99.97% DOP HEPA Filter Option for Standard 202 Unit
- 200-65 65% Bag Filter Option for Standard 200 Unit
- 202-2A 2" Mesh Prefilter Option for Standard 202 Unit
- 202-2P 2" Polyester Filters Option for Standard 202 Unit

Preventative Maintenance Pressure Gauges, etc. (when ordering main unit)

202-PG-10 0-10" magna-helic pressure gauge, approximately 5" diameter size. Surface mounted.

Replacement filters - (Quantity discounts available upon request)

- 2AF90006 Adsorber v-bank module.
- 2AF19032 Easy Clean Bag Filter
- 2AF49100 Chevron Filter
- 2AZ20004 2" Polyester Prefilter 24" x 24"
- 7FB65119 65% Short Bag Filter
- 7FB65132 65% Bag Filter
- 7FB90119 95% Short Bag Filter
- 7FB90132 95% Bag Filter
- 7FJ95112 95% @ 0.3 micron DOP filter c/w metal frame

Installation Option & Accessories

- 202-ASSY Assemble 2 Units Together Option for Standard 202 Unit
- 202-SP Source Capture Plenum Option for Standard 202 Unit
- 202-IA Additional Inlet Collar Option for Standard 202 Unit

10-07

CUSTOMER:
 CUSTOMER P.O.:
 PROJECT:
 ENGINEER:
 SALES REP.:
 IDENTIFICATION / TAGGING:



www.lev-co.com • 1.888.862.5356

The device depicted and described hereon embodies proprietary information owned by the manufacturer. All design, manufacturing, reproduction, sales and patent rights regarding this device or drawing reserved except where explicit right is guaranteed in writing. We reserve the right to make design changes.

Drawn by: JANOS-B
 Date: 5/1/2008
 Scale: NTS
 Weight: N/A

10-07 202
Filter Pack

Specification Drawing

Drawing No.: - File Name: (10-07) 203 Filter Pack - SD
 Material: Product manufactured by:  Sheet: 2/2