

SPECIFICATIONS:

CONSTRUCTION: 18 Gauge painted steel cabinet with a hinged, quick release reduced maintenance prefilter plenum. Includes a direct drive 10"x10" blower w/4-way adjustable airfoil blade exhaust grille, a totally enclosed motor, and a 6' power cord and plug.

WEIGHT: 170 lbs.

AIRFLOW: 2500 CFM (HI) / 1400 CFM (LOW)

ELECTRICAL: 3/4 HP 115/1/60, 11.4 amps, 2 speed, std.
 3/4 HP 208-230/1/60, 3.9 amps, opt. (With switch and cord, no plug).

NOISE: 68 dBA
 62 dBA with silencer (right angle discharge)

PREFILTERS: (1) 2" polyester, 10ft.² 98% bag
 (1) Auto roll, opt.
 (1) 4" pleat, opt.

MAIN FILTERS: (1) 98% bag, 66 ft.², std.
 (1) 99% bag, opt.
 (1) Easy clean, opt.

OTHER OPTIONS: Pressure gauge kit indicates filter changes
 Silencer

* This unit can be flipped over for left to right airflow.

* AFS FILTER EFFICIENCIES BASED ON ASHRAE 52-76 TEST METHOD
 ALL FLOWS STANDARD AIR AND FILTERS UNLESS OTHERWISE INDICATED

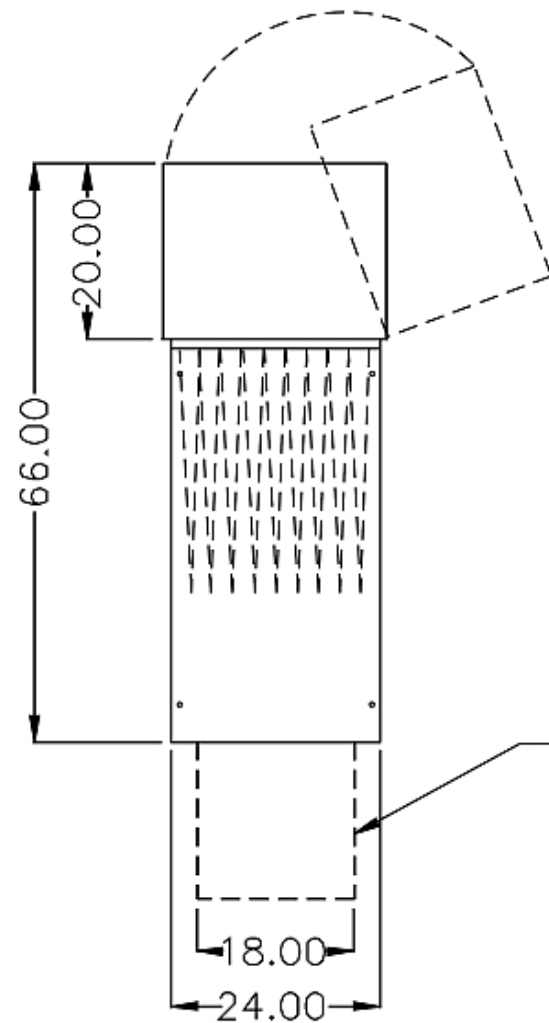

TOP VIEW

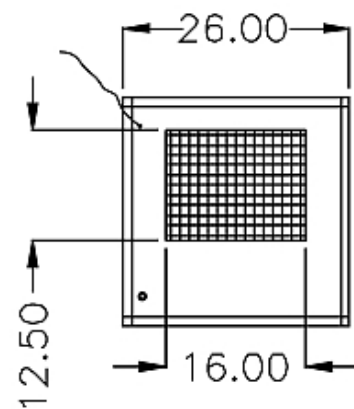

OUTLET VIEW

OPTIONAL SILENCER
 AVAILABLE STRAIGHT OR
 RIGHT ANGLE DISCHARGE

HINGED REDUCED
 MAINTENANCE
 PREFILTER
 PLENUM

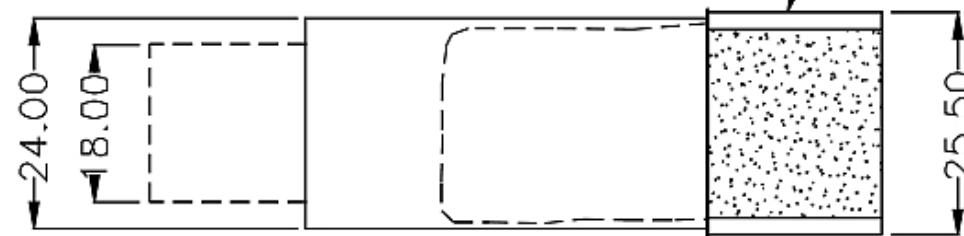

SIDE VIEW

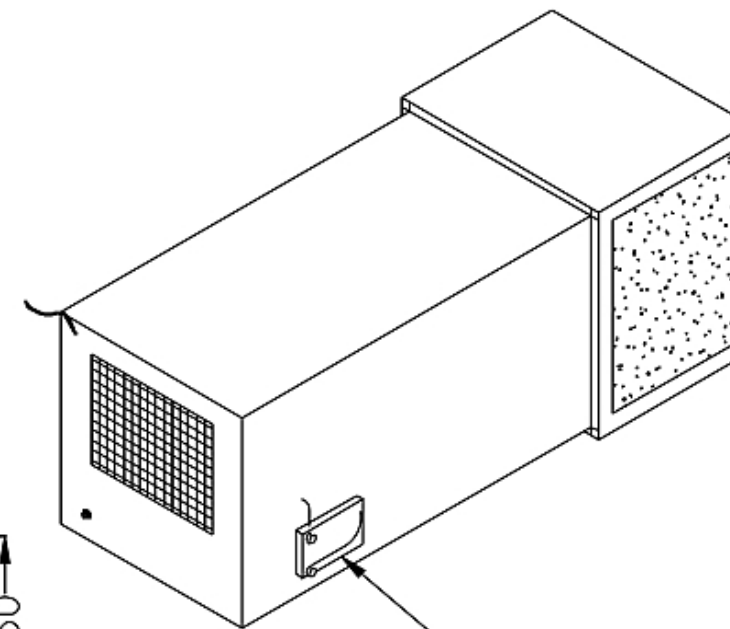

OPTIONAL
 PRESSURE
 GAGE KIT

PERFORMANCE CURVES

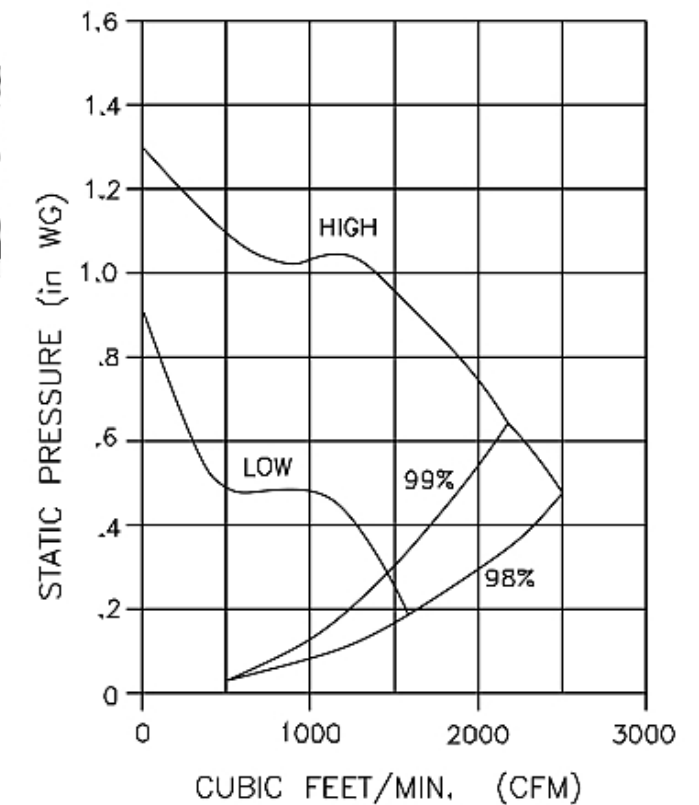

09-01

CUSTOMER:
 CUSTOMER P.O.:
 PROJECT:
 ENGINEER:
 SALES REP.:
 IDENTIFICATION / TAGGING:

> www.lev-co.com • 1.888.862.5356

lev-co

The device depicted and described hereon embodies proprietary information owned by the manufacturer. All design, manufacturing, reproduction, sales and patent rights regarding this device or drawing reserved except where explicit right is guaranteed in writing. We reserve the right to make design changes.

Drawn by: JANOS-B
 Date: 5/1/2008
 Scale: NTS
 Weight: N/A



**09-01 F70R
 AIRCLEANER**
 Specification Drawing

Drawing No.: - File Name: (09-01) F70R - SD
 Material: Product manufactured by: Sheet: 1/2

DUST COLLECTION • FUME EXTRACTION • OIL MIST FILTRATION • VEHICLE EXHAUST

Airflow
 SYSTEMS INC.

MODELS & OPTIONS

Part # Description

Main System / Part

- F70R 2500 CFM air filter unit c/w (1) 10ft² reduced maintenance pre-filter; (1) micro-glass multipocket bag filter 65% efficiency;(1) 3/4 HP totally enclosed, 2-speed motor 115/1/60Hz.

Filter Options (when ordering main unit)

- F70R-95% 99% arrestance and 95% efficiency bag filter option for standard F70R unit
- F70R-2C 2" Charcoal After-Filter Option for Standard F70R Unit
- F70R-DP Deduct Reduced Maintenance Prefilter Option for Standard F70R Unit
- F70R-EC Easy Clean Reusable Bag Filter (95% arrestance and 50% efficiency) Option for Standard F70R Unit. Recommended for applications where the material to be collected is of a coarser nature
- F70R-4PP 4" Pleated Prefilter Option for standard F70-R unit

Preventative Maintenance Pressure Gauges, etc. (when ordering main unit)

- F70R-CART Cart w/Casters Option for Standard F70R Unit
- F70R-PG-3 3" Minihelic Pressure Gauge Option for Standard F70R Unit

Misc. Options

- F70R-S-EXT Silencer-Straight Through Discharge Option for Standard F70R Unit
- F70R-SR Silencer-Right Angle Discharge Option for Standard F70R Unit

09-01

CUSTOMER:
 CUSTOMER P.O.:
 PROJECT:
 ENGINEER:
 SALES REP.:
 IDENTIFICATION / TAGGING:



The device depicted and described hereon embodies proprietary information owned by the manufacturer. All design, manufacturing, reproduction, sales and patent rights regarding this device or drawing reserved except where explicit right is guaranteed in writing. We reserve the right to make design changes.

Drawn by: JANOS-B
 Date: 5/1/2008
 Scale: NTS
 Weight: N/A

09-01 F70R AIRCLEANER
 Specification Drawing
 Drawing No.: - File Name: (09-01) F70R - SD
 Material: Product manufactured by: **Airflow SYSTEMS INC.** Sheet: 2/2