

MOTOR SPECIFICATIONS:

1100 WATTS/1.5HP/120V/1/60
FLA: 10.2 AMPS
OVERCURRENT PROTECTION
INCLUDED

NOTES:

1. NO ADDITIONAL PROTECTION REQUIRED
2. SWITCHED OUTLET MAY BE PREFERRED DEPENDING ON UNIT LOCATION

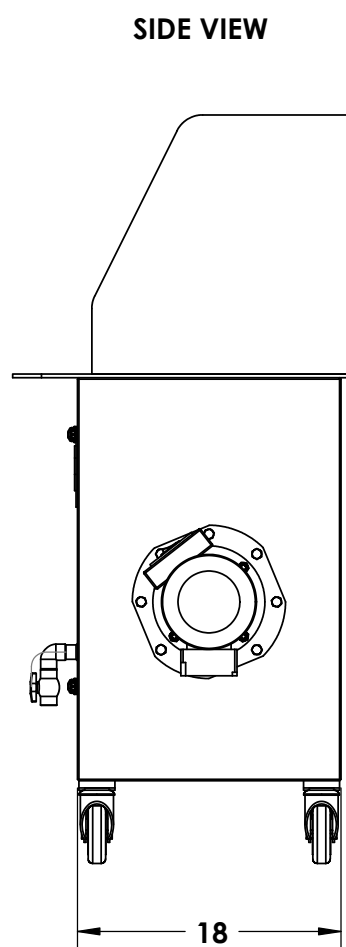
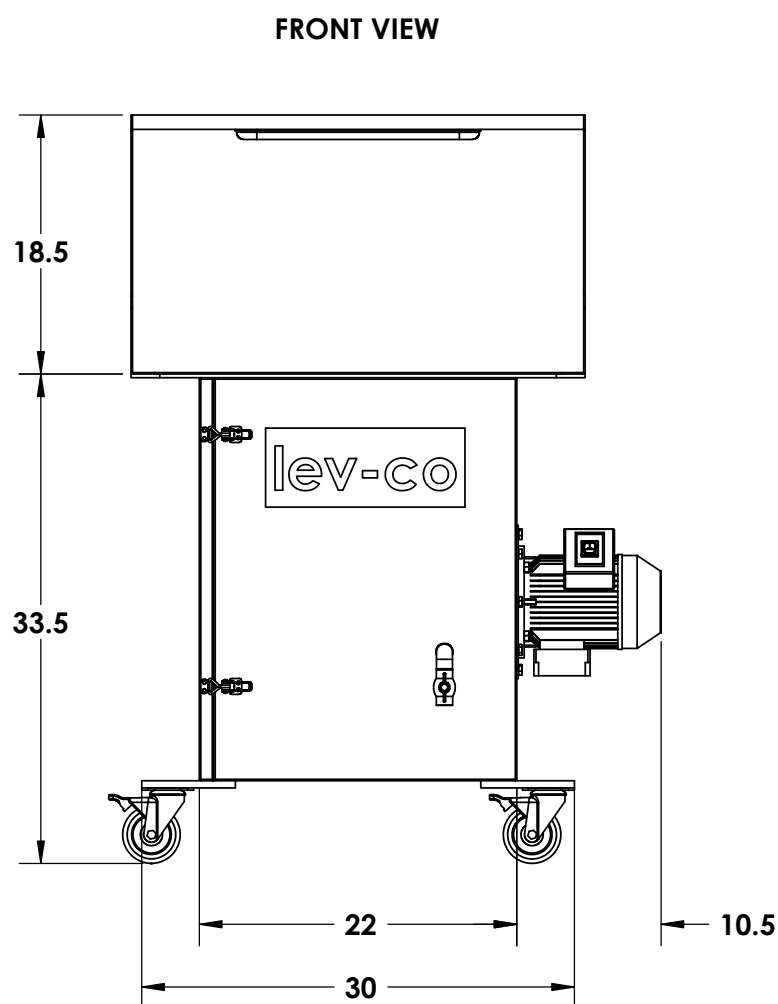
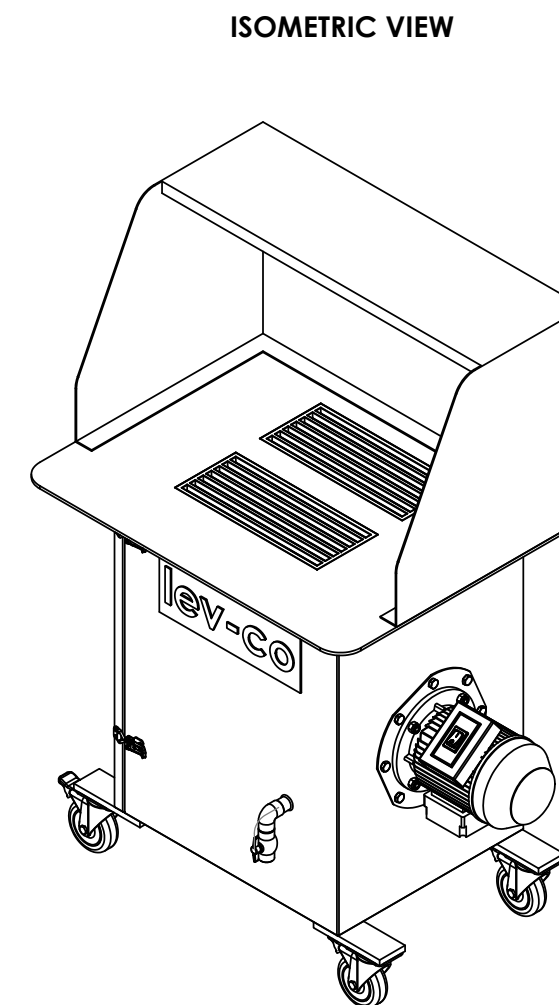
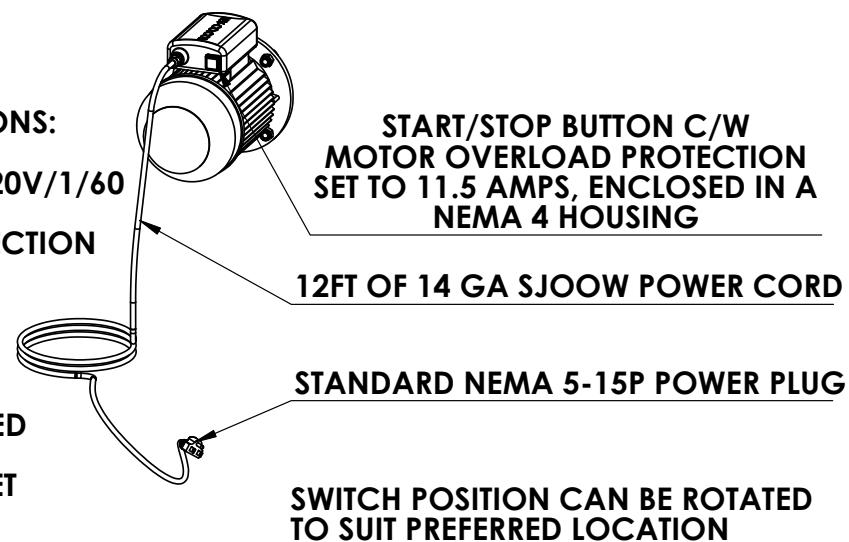

SPECIFICATION:

Construction:

- 12/14/16 ga. welded steel, powder coated cabinet

Nominal CFM:

- 1400 CFM

Filtration:

100% washable replacement prefilter, filter cartridge with 15 lbs activated carbon module (carbon included)
All steel construction (no plastic to deform or melt)
Smallest footprint (22 x 25 = 3.8ft²)
Powerful 1.1 KW (1.5HP) motor 115V/1/60 UL / CSA
Complete with Motor starter, overload protection, plug and switch
Electrically approved by CSA/ESA field evaluation.

CUSTOMER:	
CUSTOMER P.O.:	
PROJECT:	
ENGINEER:	
SALES REP.:	
IDENTIFICATION / TAGGING:	

> www.lev-co.com • 1.888.862.5356

lev-co

The device depicted and described hereon embodies proprietary information owned by the manufacturer. All design, manufacturing, reproduction, sales and patent rights regarding this device or drawing reserved except where explicit right is guaranteed in writing. We reserve the right to make design changes.

Drawn by:	Janos B
Date:	11/4/2014
Scale:	NTS
Weight:	N/A

**DCB DUCTLESS SPRAY BOOTH
1400 CFM**

Specification Drawing

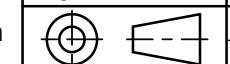

Drawing No.:	-	File Name:	(05-155) DCB - SD
Material:	-	Sheet:	1/2

MODELS & OPTIONS:

Main System / Part

- | <input type="checkbox"/> | Part # | Description |
|--------------------------|--------------------------|---|
| <input type="checkbox"/> | P-578-CF | Cleanable Down Draft Table c/w 1.5HP Fan, Switch, Plug and Wheels. AS PER CANADIAN LAW; this unit is electrically approved by CSA/ESA field evaluation. |

Misc. Options (when ordering main unit)

- | <input type="checkbox"/> | Part # | Description |
|--------------------------|-----------------------|--------------------------------------|
| <input type="checkbox"/> | P-579 | 4 wheels (for P-578 Sledgehammer) |
| <input type="checkbox"/> | P-580 | 4 legs (for P-578 Sledgehammer)125mm |

Replacement filters - (Quantity discounts available upon request)

- | <input type="checkbox"/> | Part # | Description |
|--------------------------|-----------------------|---|
| <input type="checkbox"/> | P-541 | Main Filter for "Self Cleaning" filter units (RF-SC, CF-ECO, Sledge-hammer, MF-ECO & WF-SC) |



CUSTOMER:
 CUSTOMER P.O.:
 PROJECT:
 ENGINEER:
 SALES REP.:
 IDENTIFICATION / TAGGING:

www.lev-co.com • 1.888.862.5356



The device depicted and described hereon embodies proprietary information owned by the manufacturer. All design, manufacturing, reproduction, sales and patent rights regarding this device or drawing reserved except where explicit right is guaranteed in writing. We reserve the right to make design changes.

Drawn by: Janos B
 Date: 11/4/2014
 Scale: NTS
 Weight: N/A

**DCB DUCTLESS SPRAY BOOTH
 1400 CFM**

Specification Drawing

Drawing No.: - File Name: (05-155) DCB - SD
 Material: - Sheet: 2/2

