

## SPECIFICATIONS:

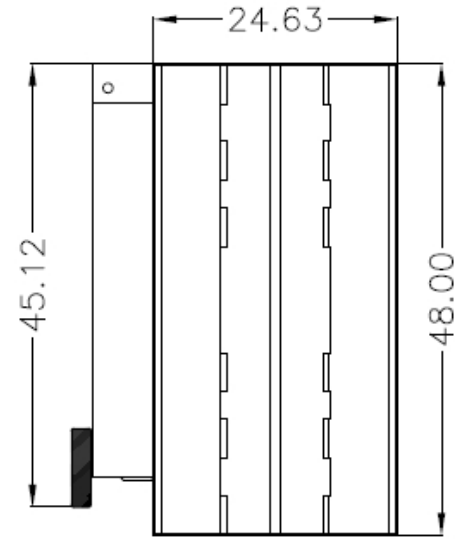

TOP VIEW  
(SHOWN LESS GRATE)

### CONSTRUCTION:

12/14/16 Gauge steel cabinet finished with Powder-Coat finish. Includes a 10 gallon external dust drawer, 5" deep aluminum downdraft table with removable aluminum back fence, removable end cap for easy access to filters, removable end panel for easy access to B.I. motor/blower, 8" wheels and 5" casters. Motor wired to junction box outside unit. Acoustical lining standard in blower compartment. Aluminum grating standard.

### WEIGHT:

366 lbs.

### DOWNDRAFT VELOCITY:

212 FPM

### NOISE:

82 dBA; 74 dBA w/silencer

### ELECTRICAL:

3 HP 208-230/460/3/60, 8.4-8.0/4.0 amps, Class II Group E

### FIRE SUPPRESSION:

Equipment provided by others.

### MAIN FILTERS:

(2) UltraClean-Plus Cartridge Filters

### AFTER FILTERS:

- (1) External HEPA filter, 99.97%, Opt.
- (1) External DOP filter, 95%, Opt.
- (1) External adsorber, 18 lb. capacity, Opt.

### OTHER OPTIONS:

- Pressure gauge kit indicates filter changes
- BF3A
- Fiberglass grate
- Silencer (Adds 8" to depth of unit)

### SPECIAL NOTES:

Meets NFPA 651 for processing and finishing aluminum when properly used and maintained, (see standard for additional requirements).

REMOVABLE ALUMINUM  
BACK FENCE, STANDARD  
(BF1A)

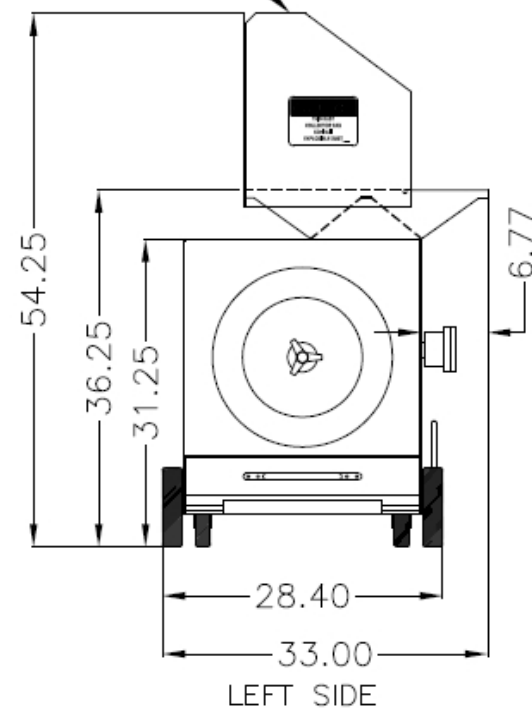

LEFT SIDE

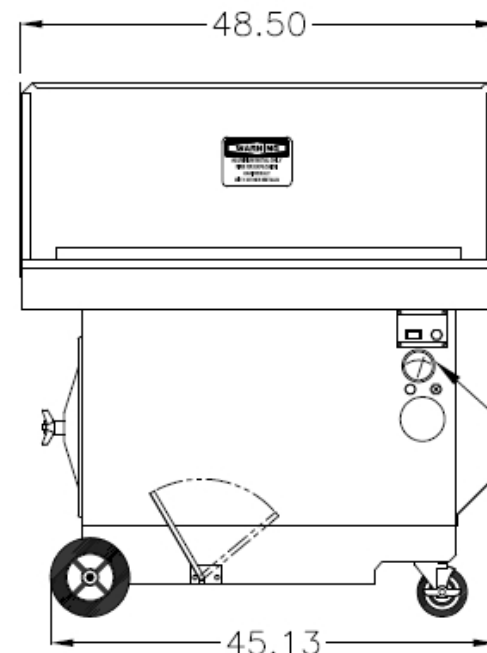

FRONT VIEW

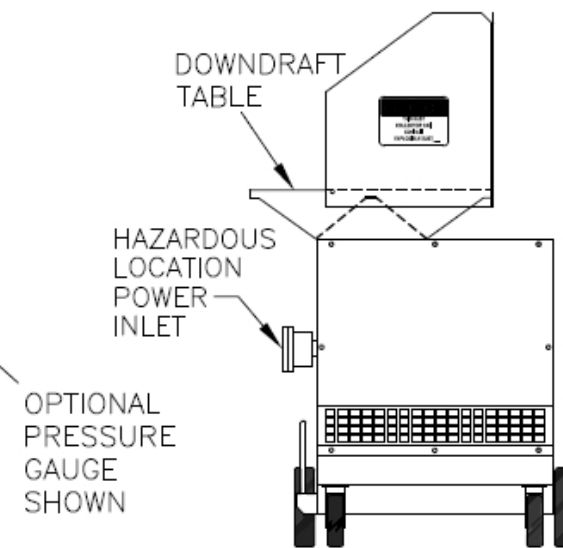

RIGHT SIDE

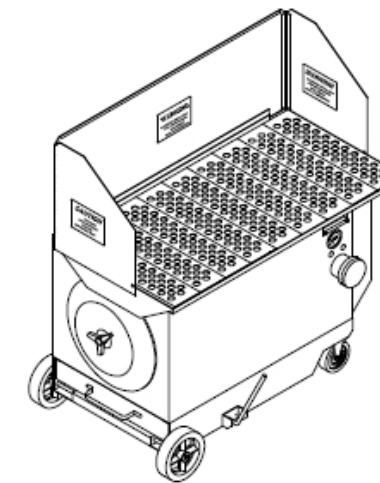

## PERFORMANCE CURVES

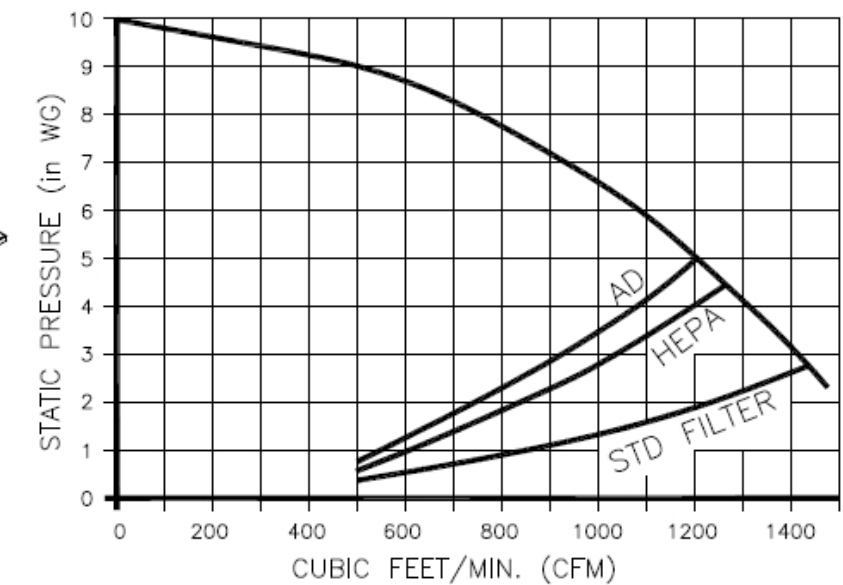

05-07

CUSTOMER:  
CUSTOMER P.O.:  
PROJECT:  
ENGINEER:  
SALES REP.:  
IDENTIFICATION / TAGGING:

> [www.lev-co.com](http://www.lev-co.com) • 1.888.862.5356

lev-co

The device depicted and described hereon embodies proprietary information owned by the manufacturer. All design, manufacturing, reproduction, sales and patent rights regarding this device or drawing reserved except where explicit right is guaranteed in writing. We reserve the right to make design changes.

Drawn by: Janos B  
Date: 5/1/2008  
Scale: NTS  
Weight: N/A

05-07 ALH2  
Downdraft Table  
Specification Drawing



Drawing No.: - File Name: (05-07) ALH2 - SD

Material: Product manufactured by: Sheet: 1/2

**Airflow**  
SYSTEMS INC.

DUST COLLECTION • FUME EXTRACTION • OIL MIST FILTRATION • VEHICLE EXHAUST

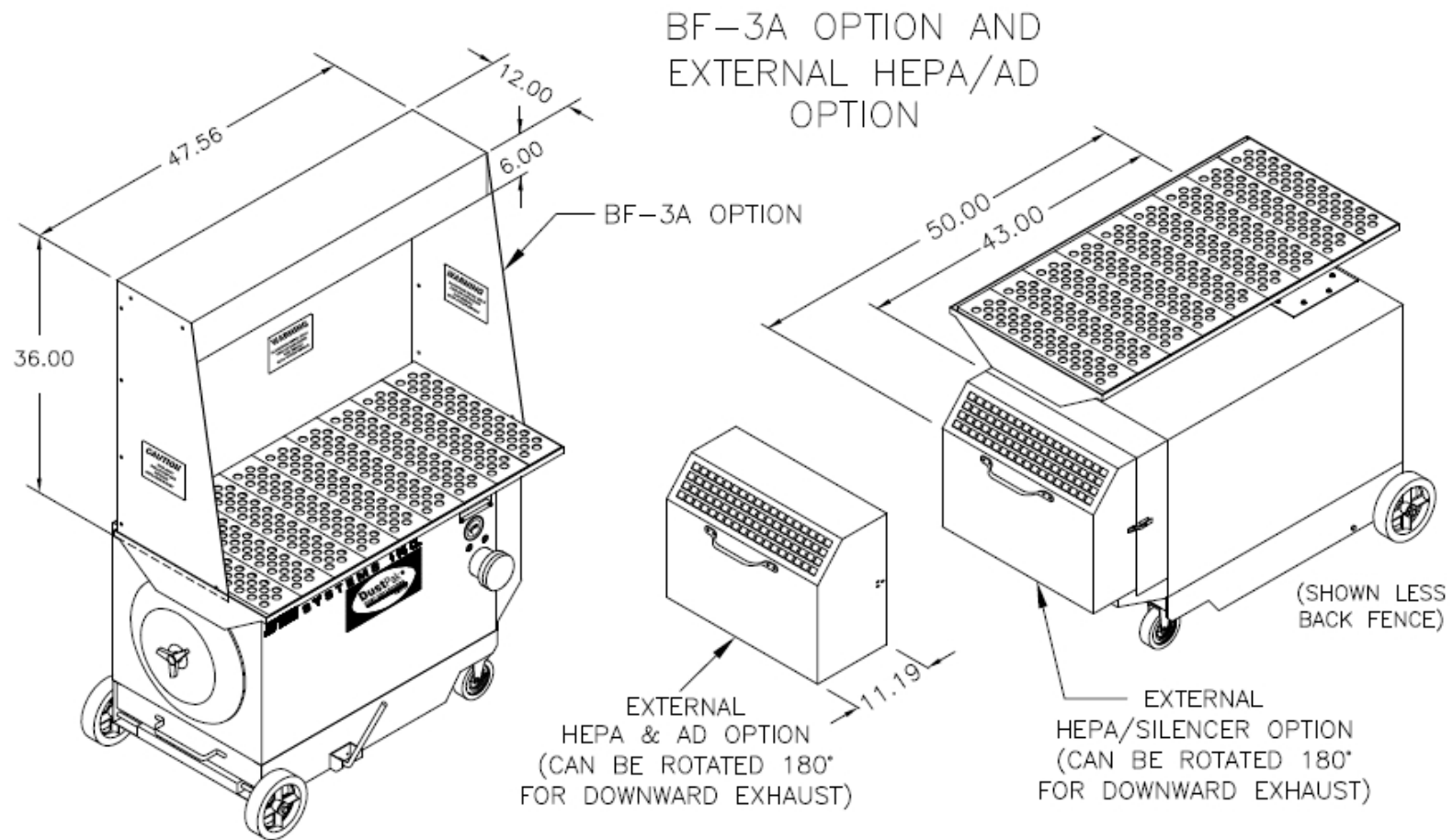

**MODELS & OPTIONS:**

**Part # Description**

**Main System / Part**

- ALH2-1 1200 cfm portable downdraft table to collect aluminum dust, 24" deep x 48" wide work surface at 36.25" height. 208 fpm downdraft velocity, with 12" tall aluminum side & back shields and aluminum grate panels. Contains (2) ULTRACLEAN-PLUS™ cartridge filter. (150 sq.ft. each) and a 3 Hp Group E motor. 208-230/460/3/60 Hz (8.4-8/4 amps). Electrical components meet NFPA requirements for Class II, Group-E. (ALUMINUM DUST). 79 dBA.
- ALH2-2 1200 cfm portable downdraft table to collect aluminum dust, 24" deep x 48" wide work surface at 36.25" height. 208 fpm downdraft velocity, with 12" tall aluminum side & back shields and aluminum grate panels. Contains (2) ULTRACLEAN-PLUS™ cartridge filter. (150 sq.ft. each) and a 3 Hp Group E motor. 575/3/60 Hz (8.4-8/4 amps). Electrical components meet NFPA requirements for Class II, Group-E. (ALUMINUM DUST). 79 dBA.

**Filter Options (when ordering main unit)**

- ALH2-EXAD External AD Module Filter Option for Standard ALH-2 Unit
- ALH2-EXDOP External 95% DOP Filter Option for Standard ALH-2 Unit
- ALH2-EXHE External 99.97% HEPA Filter Option for Standard ALH-2 Unit
- ALH2-HE/AD Kit using EXTERNAL HEPA and EXTERNAL AD options.

**Preventative Maintenance Pressure Gauges, etc. (when ordering main unit)**

- ALH2-PG-6 0-6" magna-helic pressure gauge, approximately 5" diameter size. Surface mounted.

**Misc. Options**

- ALH2-FIBER Fiberglass Bar Grate Option for Standard ALH-2 Unit

**Sound Attenuation**

- ALH2-S-EXT External Silencer Option for Standard ALH-2 Unit

**Localized Enclosures and Shields**

- ALH2-BF3A Aluminum Enclosure, 36" High, Sides, Back & Top Option for Standard ALH-2 Unit

05-07

CUSTOMER:  
 CUSTOMER P.O.:  
 PROJECT:  
 ENGINEER:  
 SALES REP.:  
 IDENTIFICATION / TAGGING:

> [www.lev-co.com](http://www.lev-co.com) • 1.888.862.5356

**lev-co**

The device depicted and described hereon embodies proprietary information owned by the manufacturer. All design, manufacturing, reproduction, sales and patent rights regarding this device or drawing reserved except where explicit right is guaranteed in writing. We reserve the right to make design changes.

Drawn by: Janos B  
 Date: 5/1/2008  
 Scale: NTS  
 Weight: N/A

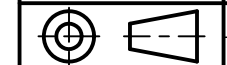

**05-07 ALH2  
 Downdraft Table**

Specification Drawing

Drawing No.: - File Name: (05-07) ALH2 - SD

Material: Product manufactured by: Sheet: 2/2

