

1. WALL_FLEX WITH DUCT CONNECTION

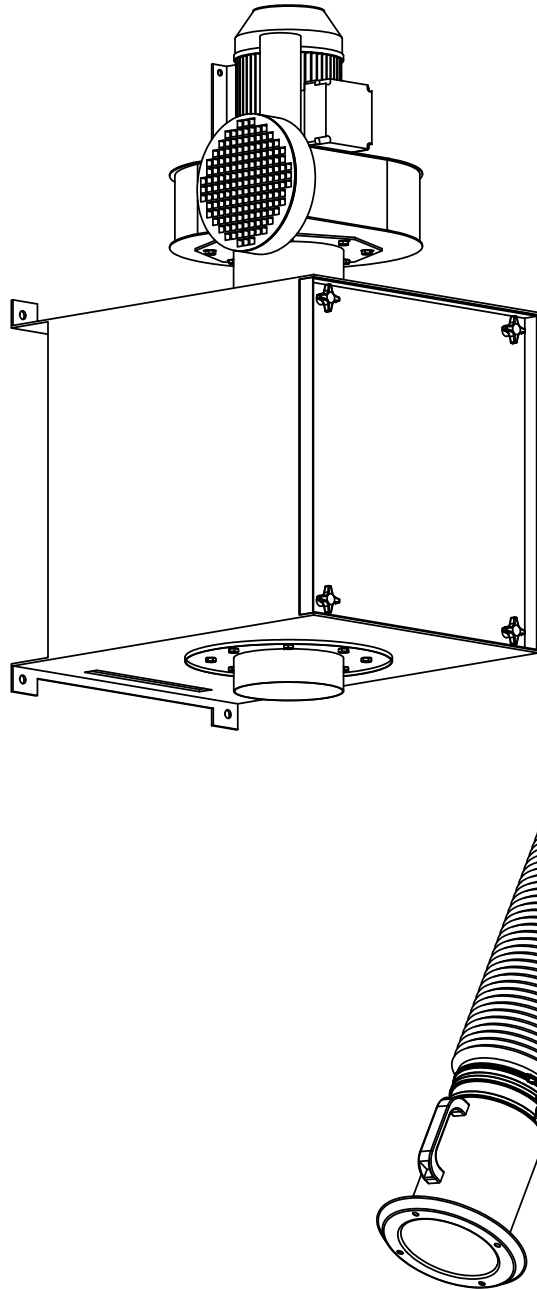

2. WALL_FLEX WITH FLEXI ARM

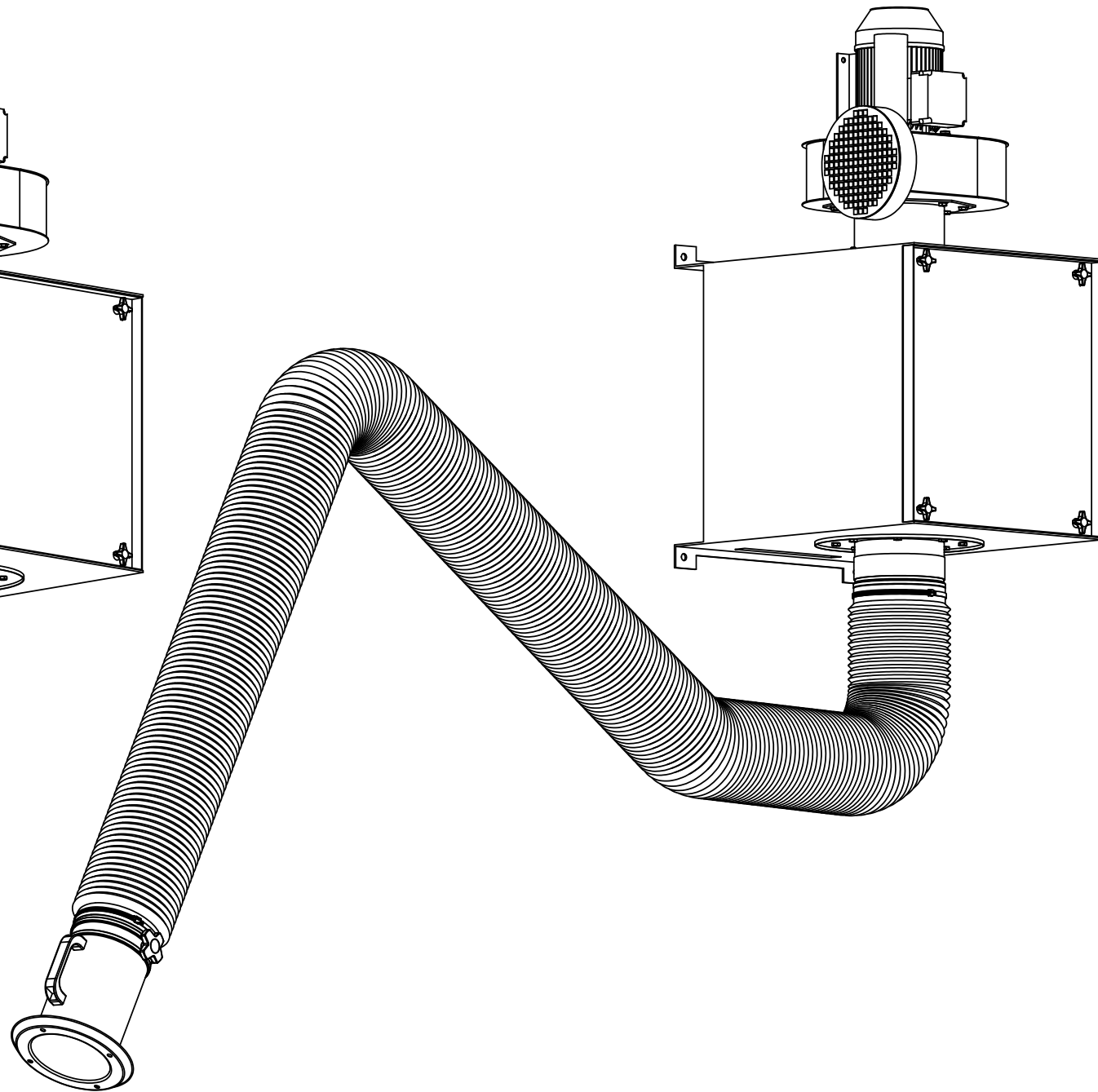

3. "INVERTED" WALL_FLEX WITH FLEXI ARM

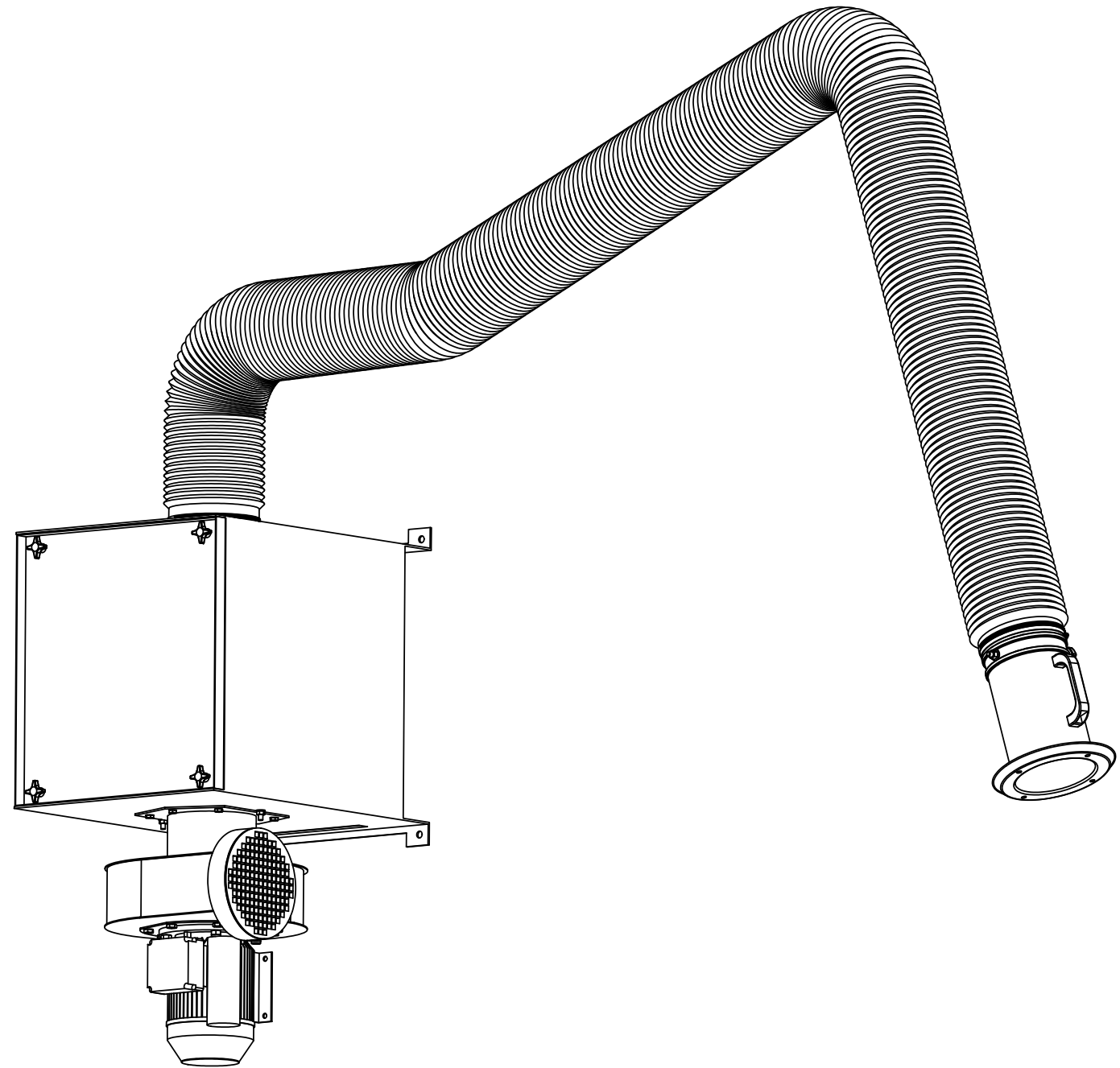

CUSTOMER:
 CUSTOMER P.O.:
 PROJECT:
 ENGINEER:
 SALES REP.:
 IDENTIFICATION / TAGGING:

> www.lev-co.com • 1.888.862.5356

lev-co

The device depicted and described hereon embodies proprietary information owned by the manufacturer. All design, manufacturing, reproduction, sales and patent rights regarding this device or drawing reserved except where explicit right is guaranteed in writing. We reserve the right to make design changes.

Drawn by: Janos B
 Date: 7/2/2014
 Scale: NTS
 Weight: N/A

**03-05 WALL-FLEX
 CARTRIDGE DUST COLLECTOR**
 Specification Drawing

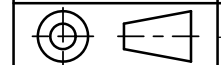

Drawing No.: -
 Material: -
 File Name: (03-05) WALL-FLEX - SD
 Sheet: 1/5

SIDE VIEW

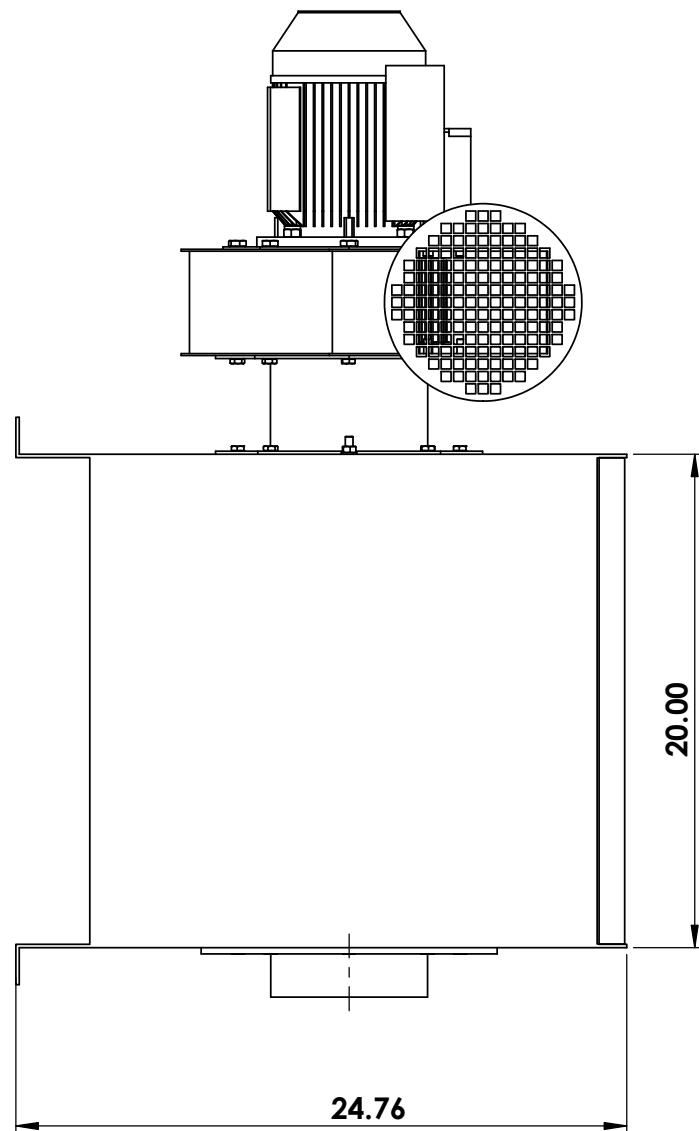

FRONT VIEW

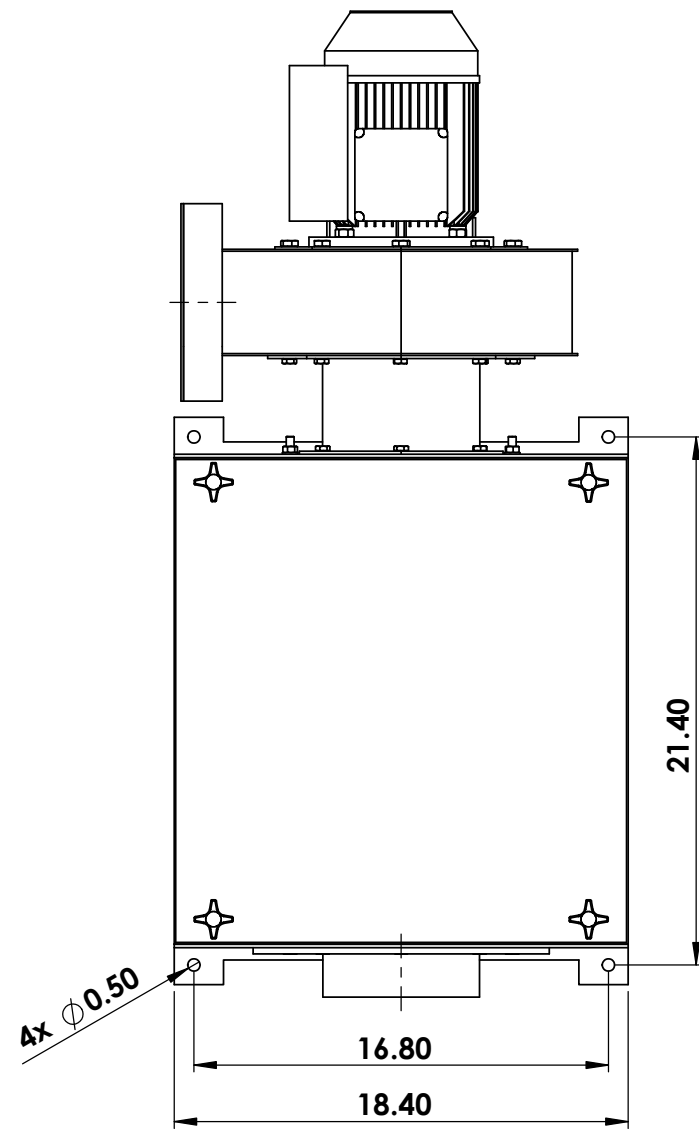

PERFORMANCE CURVE

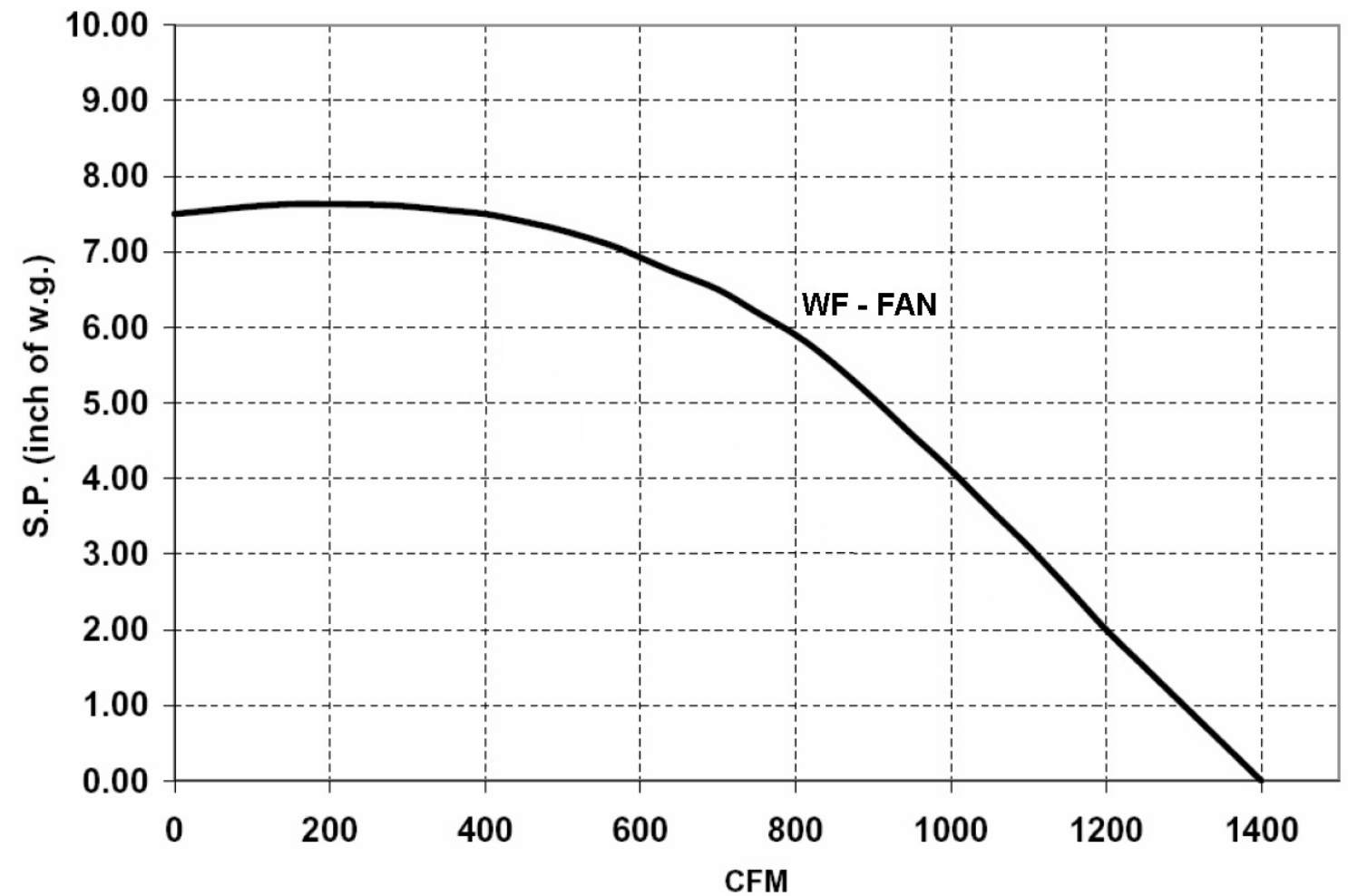

CUSTOMER:
 CUSTOMER P.O.:
 PROJECT:
 ENGINEER:
 SALES REP.:
 IDENTIFICATION / TAGGING:

> www.lev-co.com • 1.888.862.5356

lev-co

The device depicted and described hereon embodies proprietary information owned by the manufacturer. All design, manufacturing, reproduction, sales and patent rights regarding this device or drawing reserved except where explicit right is guaranteed in writing. We reserve the right to make design changes.

Drawn by: Janos B
 Date: 7/2/2014
 Scale: NTS
 Weight: N/A

**03-05 WALL-FLEX
 CARTRIDGE DUST COLLECTOR**
 Specification Drawing

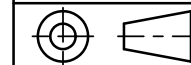

Drawing No.: -
 Material: -
 File Name: (03-05) WALL-FLEX - SD
 Sheet: 2/5

DUAL ARM CONFIGURATION

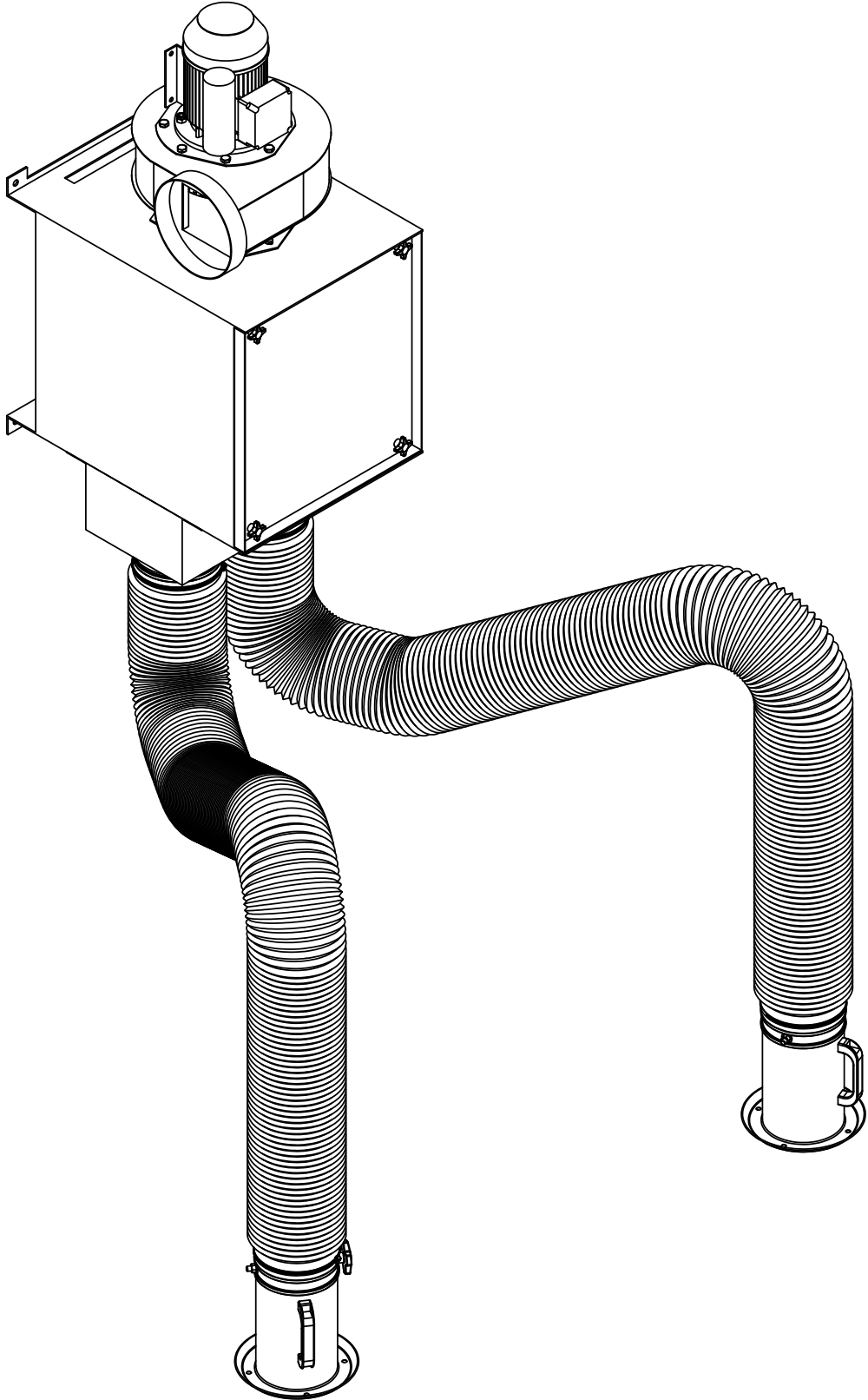
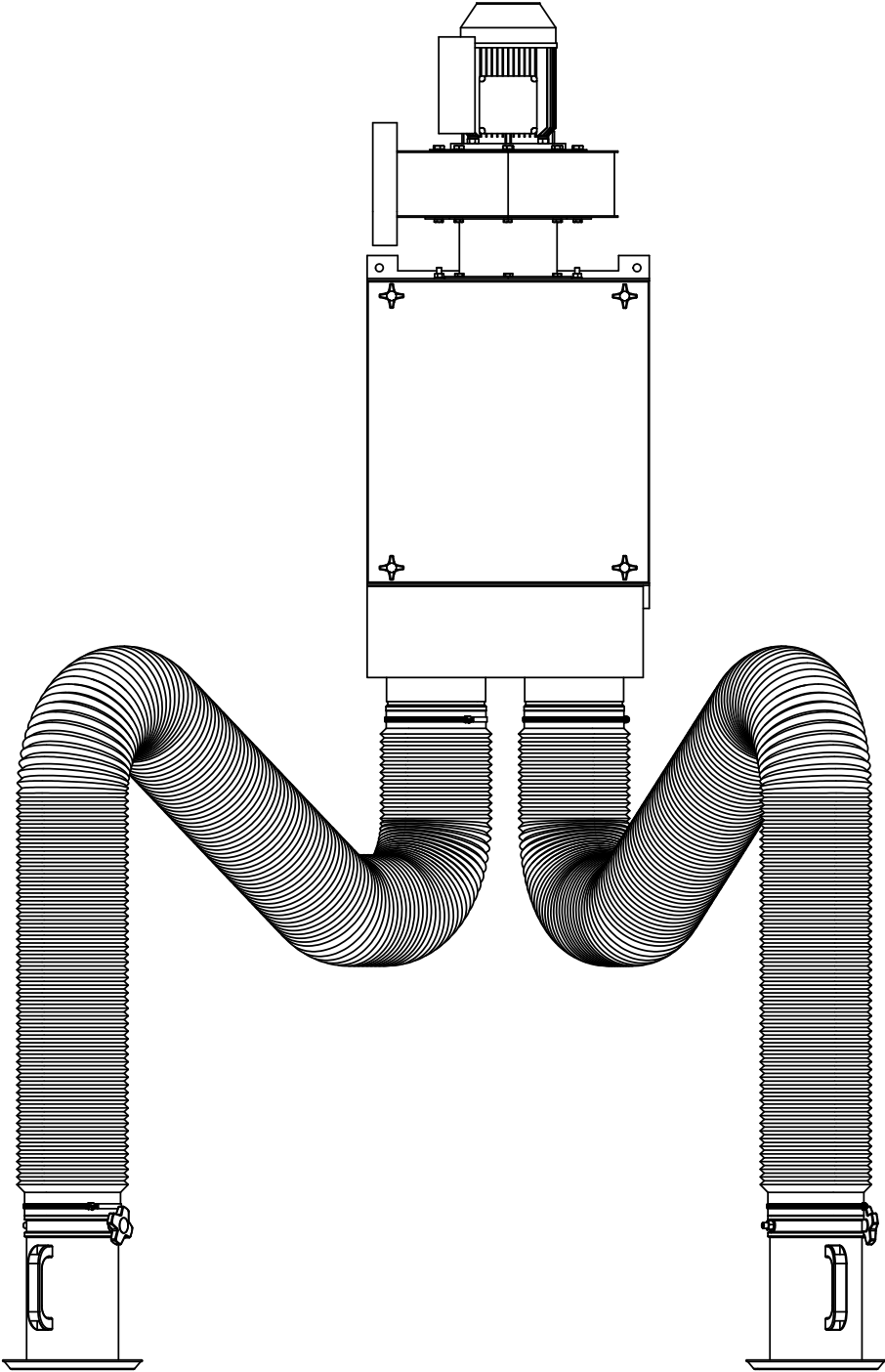
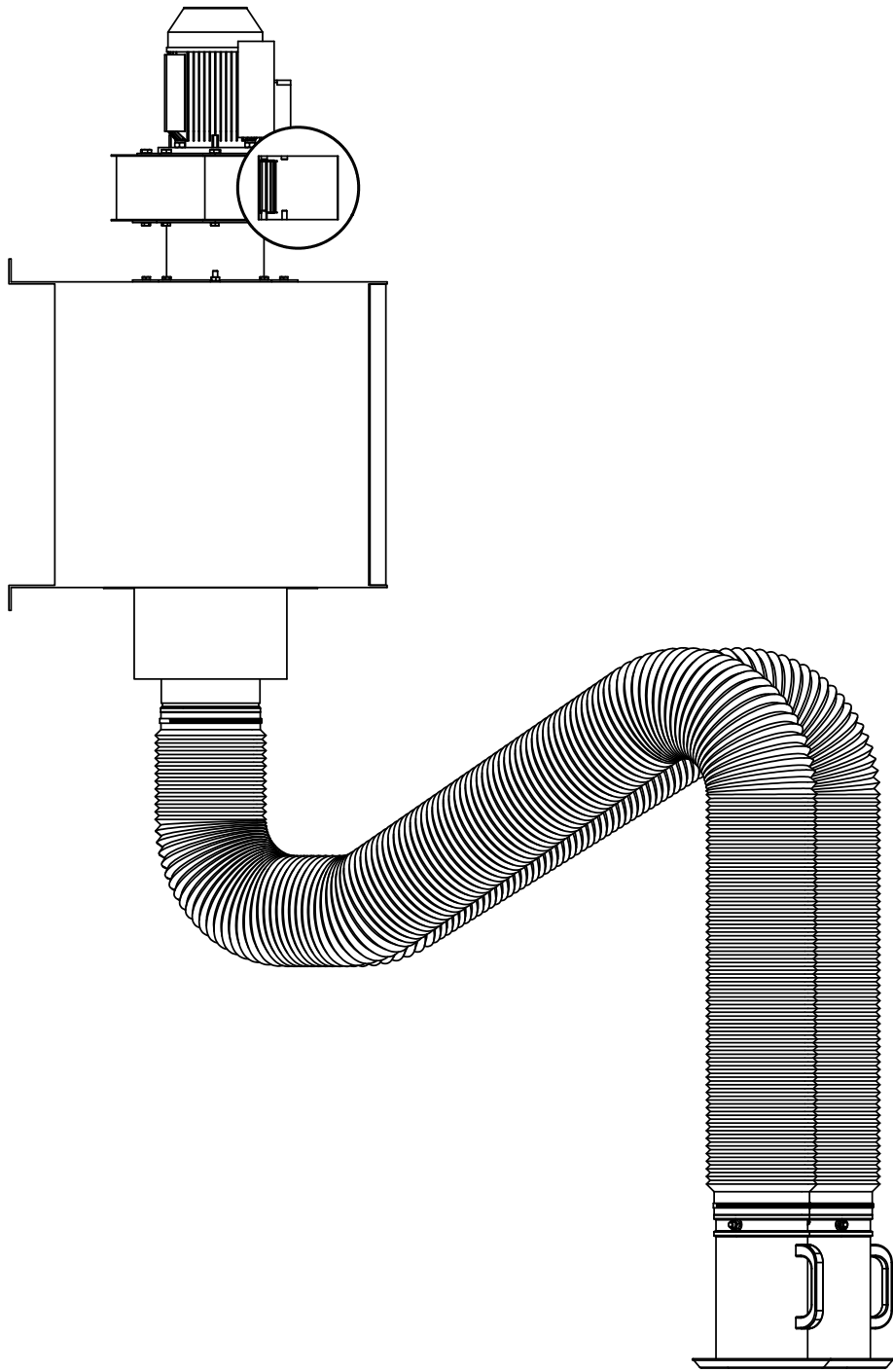

CUSTOMER:	
CUSTOMER P.O.:	
PROJECT:	
ENGINEER:	
SALES REP.:	
IDENTIFICATION / TAGGING:	

www.lev-co.com • 1.888.862.5356



The device depicted and described hereon embodies proprietary information owned by the manufacturer. All design, manufacturing, reproduction, sales and patent rights regarding this device or drawing reserved except where explicit right is guaranteed in writing. We reserve the right to make design changes.

Drawn by:	Janos B
Date:	7/2/2014
Scale:	NTS
Weight:	N/A

03-05 WALL-FLEX CARTRIDGE DUST COLLECTOR Specification Drawing	
Drawing No.:	-
Material:	-
File Name:	(03-05) WALL-FLEX - SD
Sheet:	3/5

"INVERTED" DUAL ARM CONFIGURATION

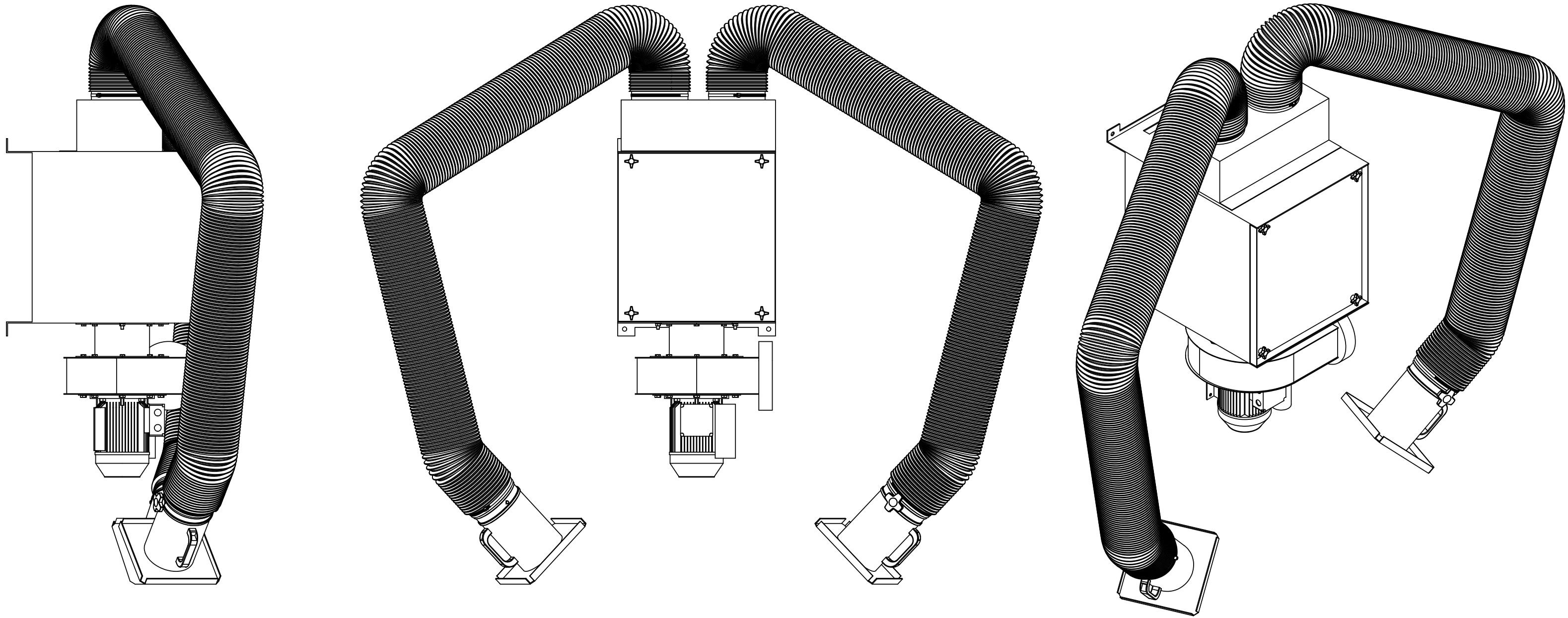

CUSTOMER:
 CUSTOMER P.O.:
 PROJECT:
 ENGINEER:
 SALES REP.:
 IDENTIFICATION / TAGGING:

> www.lev-co.com • 1.888.862.5356



The device depicted and described hereon embodies proprietary information owned by the manufacturer. All design, manufacturing, reproduction, sales and patent rights regarding this device or drawing reserved except where explicit right is guaranteed in writing. We reserve the right to make design changes.

Drawn by: Janos B
 Date: 7/2/2014
 Scale: NTS
 Weight: N/A

**03-05 WALL-FLEX
 CARTRIDGE DUST COLLECTOR**
 Specification Drawing

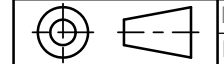

Drawing No.: -
 Material: -
 File Name: (03-05) WALL-FLEX - SD
 Sheet: 4/5

MODELS & OPTIONS:

Main System - Wall-Flex - Standard Component Configuration

Part #	Description
<input type="checkbox"/> WF-1	Wall Flex high efficiency filtration system c/w 1.5 HP direct mount P-Max fan 115/1/60 TEFC motor.
<input type="checkbox"/> WF-2	Wall Flex high efficiency filtration system c/w 2 HP direct mount P-Max fan 230/3/60 TEFC motor.
<input type="checkbox"/> WF-3	Wall Flex high efficiency filtration system c/w 2 HP direct mount P-Max fan 575/3/60 TEFC motor.
<input type="checkbox"/> WF-4	Wall Flex high efficiency filtration system c/w 2 HP direct mount P-Max fan 230/1/60 TEFC motor.

Main System - Wall-Flex - Filter Gas/Micro - Combo Filter Configuration

Part #	Description
<input type="checkbox"/> WF-1/P-004-WFC	Wall Flex high efficiency filtration system c/w 1.5 HP direct mount P-Max fan 115/1/60 TEFC motor and Filter Gas/Micro-Combo Filter (P-004-WFC filter with 12-15 lbs of charcoal included) instead of standard P-160 Filter
<input type="checkbox"/> WF-2/P-004-WFC	Wall Flex high efficiency filtration system c/w 2 HP direct mount P-Max fan 230/460/3/60 TEFC motor and Filter Gas/Micro-Combo Filter (P-004-WFC filter with 12-15 lbs of charcoal included) instead of standard P-160 Filter
<input type="checkbox"/> WF-3/P-004-WFC	Wall Flex high efficiency filtration system c/w 2 HP direct mount P-Max fan 575/3/60 TEFC motor and Filter Gas/Micro-Combo Filter (P-004-WFC filter with 12-15 lbs of charcoal included) instead of standard P-160 Filter
<input type="checkbox"/> WF-4/P-004-WFC	Wall Flex high efficiency filtration system c/w 2 HP direct mount P-Max fan 230/1/60 TEFC motor and Filter Gas/Micro-Combo Filter (P-004-WFC filter with 12-15 lbs of charcoal included) instead of standard P-160 Filter

Main System Part - Pre-engineered Kits - Cleanable filters

Part #	Description
<input type="checkbox"/> WF-CF-7	Wall Flex Base Model w/ 7' Extraction Arm
<input type="checkbox"/> WF-CF-10	Wall Flex high efficiency filter system c/w 1.5 HP fan 115/1/60 TEFC, switch, overload, plug, cord & 10' extraction arm
<input type="checkbox"/> WF-CF-14	Wall Flex high efficiency filter system c/w 1.5 HP fan 115/1/60 TEFC, switch, overload, plug, cord & 14' extraction arm
<input type="checkbox"/> WF-CF-17	Wall Flex high efficiency filter system c/w 1.5 HP fan 115/1/60 TEFC, switch, overload, plug, cord & 17' extraction arm

Extraction Arms

Part #	Description
<input type="checkbox"/> P-006	Flexi-I Extraction Arm 160mm (6.5")Ø – 1.5m (5')L. c/w damper and wall/Fan bracket.
<input type="checkbox"/> P-007	Flexi-I Extraction Arm 160mm (6.5")Ø – 2m (7')L. c/w damper and wall/Fan bracket.
<input type="checkbox"/> P-008	Flexi-I Extraction Arm 160mm (6.5")Ø – 3m (10')L. c/w damper and wall/Fan bracket.
<input type="checkbox"/> P-009	Flexi-I Extraction Arm 160mm (6.5")Ø – 4m (14')L. c/w damper and wall/Fan bracket.
<input type="checkbox"/> P-010	Flexi-I Extraction Arm 160mm (6.5")Ø – 5m (17')L. c/w damper and wall/Fan bracket.
<input type="checkbox"/> P-143	Flexi-II Extraction Arm: 200mm (8")Ø – 2m (07')L. c/w damper and wall/Fan bracket.
<input type="checkbox"/> P-144	Flexi-II Extraction Arm: 200mm (8")Ø – 3m (10')L. c/w damper and wall/Fan bracket.
<input type="checkbox"/> P-145	Flexi-II Extraction Arm: 200mm (8")Ø – 4m (14')L. c/w damper and wall/Fan bracket.
<input type="checkbox"/> P-146	Flexi-II Extraction Arm: 200mm (8")Ø – 5m (17')L. c/w damper and wall/Fan bracket.

Variable frequency drives

Part #	Description
<input type="checkbox"/> JRP-VFD-230V-2-NEMA4	2.0 HP AC DRIVE ,230V 1 PH IN 3 PH OUT in NEMA4 enclosure and simple "Dial/Potentiometer" speed control.

Stanchions & Wall Brackets

Part #	Description
<input type="checkbox"/> P-023	Ceiling/floor stanchion 3m (9.75') for Flexi and Pro-Flex Extraction Arms

Hose Connectors and Fittings

Part #	Description
<input type="checkbox"/> R-060	Inlet Ø125 galvanized, 8 bolts M8 x 16mm. Packed in plastic.
<input type="checkbox"/> R-061	Inlet Ø150/160 powder coated black, 8 bolts M8 x 16mm. Packed in plastic.
<input type="checkbox"/> R-062	Inlet Ø200 powder coated black, 8 bolts M8 x 16mm. Packed in plastic.
<input type="checkbox"/> R-063	Inlet Ø100 powder coated black, 8 bolts M8 x 16mm. Packed in plastic.
<input type="checkbox"/> R-064	Inlet Ø75 powder coated black, 8 bolts M8 x 16mm. Packed in plastic.

Silencer Option (when ordering main unit)

Part #	Description
<input type="checkbox"/> SIL-8	Silencer for P-Max series fan, 8 (200mm) (for use with P-Max Fans)

Installation Accessories

Part #	Description
<input type="checkbox"/> P-086	Double arm Adapter, which permits 2-160mm Flexi arms to be mounted on Ceiling, Table, or portable collector such as a Mobi-Flex.

Replacement filters - (Quantity discounts available upon request)

Part #	Description
<input type="checkbox"/> P-537	Replacement filter Rectangular for P-150, Roll Flex
<input type="checkbox"/> P-160	80/20 Cell Polyester blended replacement filter cartridge for standard Mobi-Flex units Dry Dust & Welding smoke applications. Cleanable with vacuum or compressed air.
<input type="checkbox"/> P-160-OEM	OEM Replacement filter for Mobi-Flex. Washable spun-bound polyester. Cleanable with Detergent and high pressure water.
<input type="checkbox"/> Charcoal-15	15 lbs. Bag of activated carbon.
<input type="checkbox"/> Charcoal-CP40	40" lb of CP Blend of chemisorbant and activated carbon blend.
<input type="checkbox"/> P-160-TEF	Target Contaminants: Hydrocarbons, VOC's, Oxides of sulfur, Formaldehyde, Nitric Oxide, Hydrogen Sulfide, Lower molecular weight aldehydes and organic acids
<input type="checkbox"/> P-004-MFC-18	Teflon Filter for Mobi Flex and Wall Flex filter units. 99.97% @ 0.5 Micons... Washable
<input type="checkbox"/> P-004-WFC-16	Filter, Gas/Micro - Combo Filter - spun bond polyester/activated carbon (comes with 15 lbs. of activated charcoal in pail)
<input type="checkbox"/> P-004-WFC-16	Filter, Gas/Micro - Combo Filter - spun bond polyester/activated carbon (comes with 12-15 lbs. of activated charcoal in pale)

CUSTOMER:
CUSTOMER P.O.:
PROJECT:
ENGINEER:
SALES REP.:
IDENTIFICATION / TAGGING:

www.lev-co.com • 1.888.862.5356



The device depicted and described hereon embodies proprietary information owned by the manufacturer. All design, manufacturing, reproduction, sales and patent rights regarding this device or drawing reserved except where explicit right is guaranteed in writing. We reserve the right to make design changes.

Drawn by:	Janos B
Date:	7/2/2014
Scale:	NTS
Weight:	N/A

03-05 WALL-FLEX CARTRIDGE DUST COLLECTOR	
Specification Drawing	
Drawing No.: -	File Name: (03-05) WALL-FLEX - SD
Material: -	Sheet: 5/5