

SPECIFICATIONS:

CONSTRUCTION: 12/14/16 Gauge steel cabinet finished with Powder-Coat Finish, Includes a 5 gallon external dust drawer, removable end cap for easy access to filter, removable panel for easy access to direct drive motor/blower, 25' 12 Ga. power cord, and on-off switch. Motor wired to junction box outside unit for 3 phase option. Acoustical lining standard in blower compartment, Vibra-Pulse cleaning standard,

WEIGHT: 200 lbs.
AIRFLOW: 600 CFM with std. 1 HP motor
 800 CFM with opt. 1.5 HP motor
NOISE: 71 dBA
ELECTRICAL: 1 HP 115 /1/60, 12 amps, std.
 1.5 HP 115/220/1/60, 15/7,9-7,5 amps, opt.
 1.5 HP 230/460/3/60, 4,9-4,6/2,3 amps, opt.

FIRE SUPPRESSION: Equipment provided by others.
SPECIAL NOTES: Compressed air filter provided by others.

MAIN FILTERS: (1) CLEAN-2 Filter cartridge, 16"Dx12", Std.
 (1) Cartridge, FIBERDUST , Opt.
 (1) Cartridge, Spark Resistant, Opt.
 (1) Cartridge, Spunbond - HO, Opt.
 (1) Cartridge, CleanPlus double treated fire retardant, Opt.

HEPA OPTIONS: (1) External HEPA filter, 99,97%

AD OPTION: (1) External adsorber, 25 lb. capacity

OTHER OPTIONS: Pressure gauge kit indicates filter changes
 Hopper option, 10 Gallon
 Auto Clean, (w/Hopper opt.)
 Regulator
 Silencer (Adds 3" to depth of unit)

* AFS FILTER EFFICIENCIES BASED ON ASHRAE 52-76 TEST METHOD

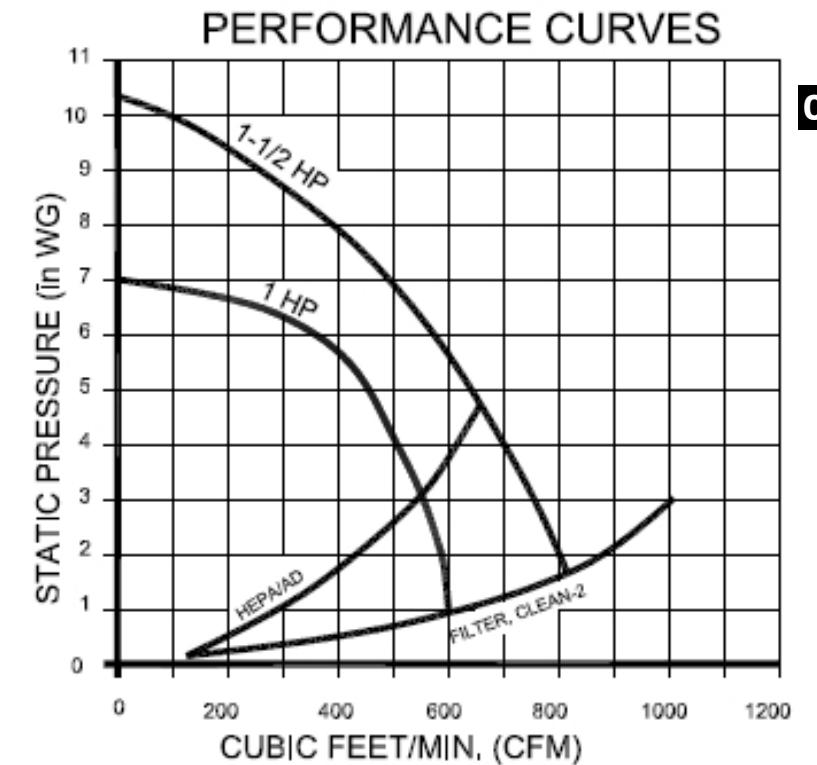
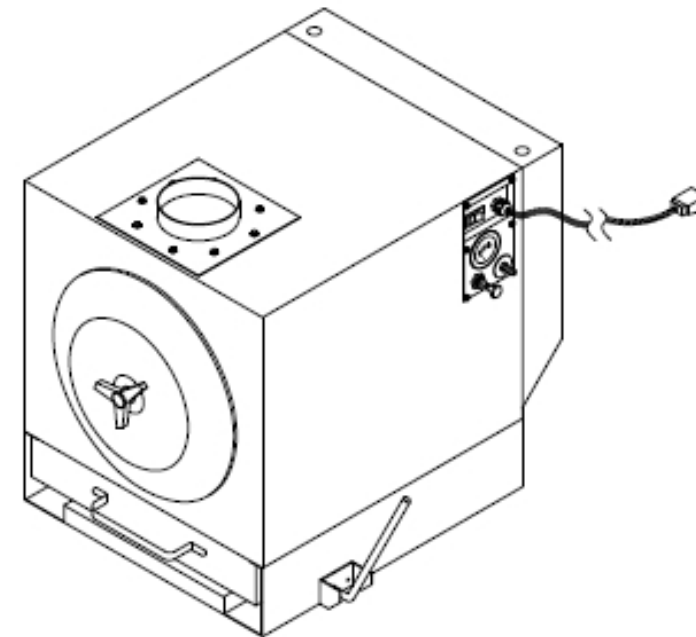
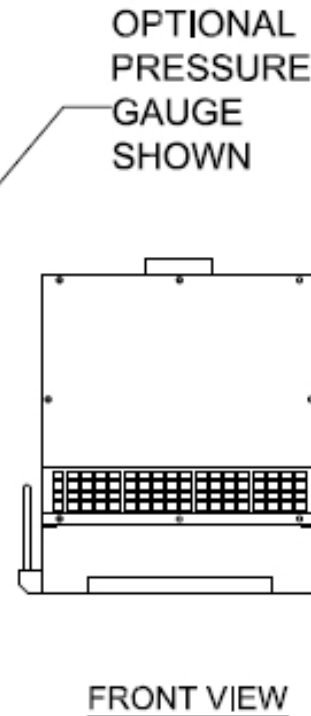
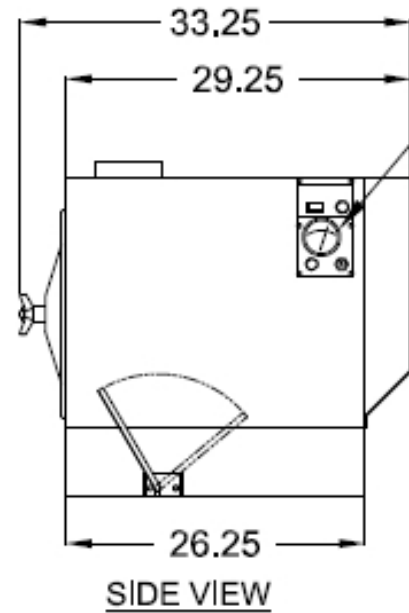
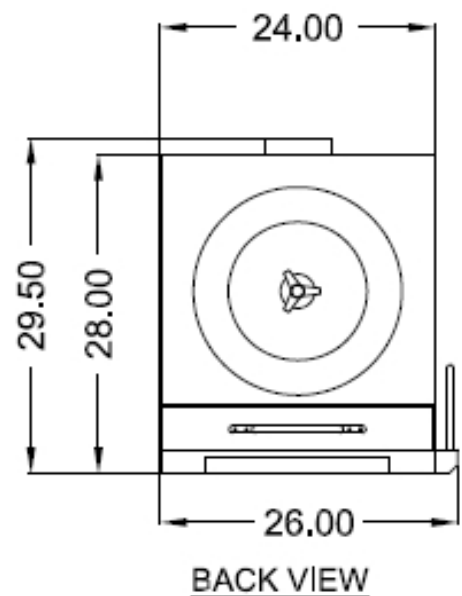
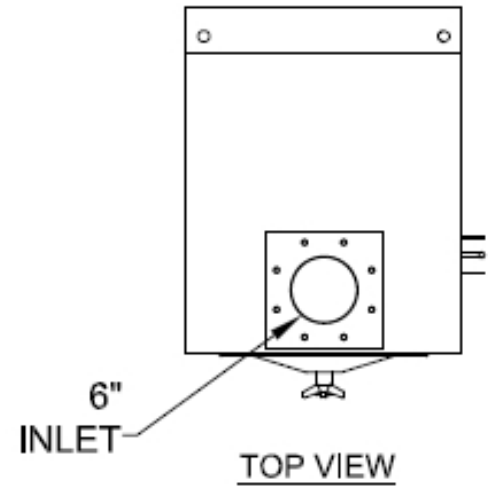

03-01

CUSTOMER:
 CUSTOMER P.O.:
 PROJECT:
 ENGINEER:
 SALES REP.:
 IDENTIFICATION / TAGGING:

> www.lev-co.com • 1.888.862.5356

lev-co

The device depicted and described hereon embodies proprietary information owned by the manufacturer. All design, manufacturing, reproduction, sales and patent rights regarding this device or drawing reserved except where explicit right is guaranteed in writing. We reserve the right to make design changes.

Drawn by: Janos-B
 Date: 3/31/2011
 Scale: NTS
 Weight: N/A

03-01DCH-1
c/w External Tray or Hopper
 Specification Drawing

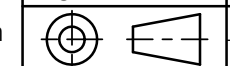

Drawing No.: -
 Material: -
 File Name: (03-01) DCH-1 - SD
 Sheet: 1/2

HOPPER OPTION AND EXTERNAL HEPA/SILENCER OPTION

DCH-1-H10

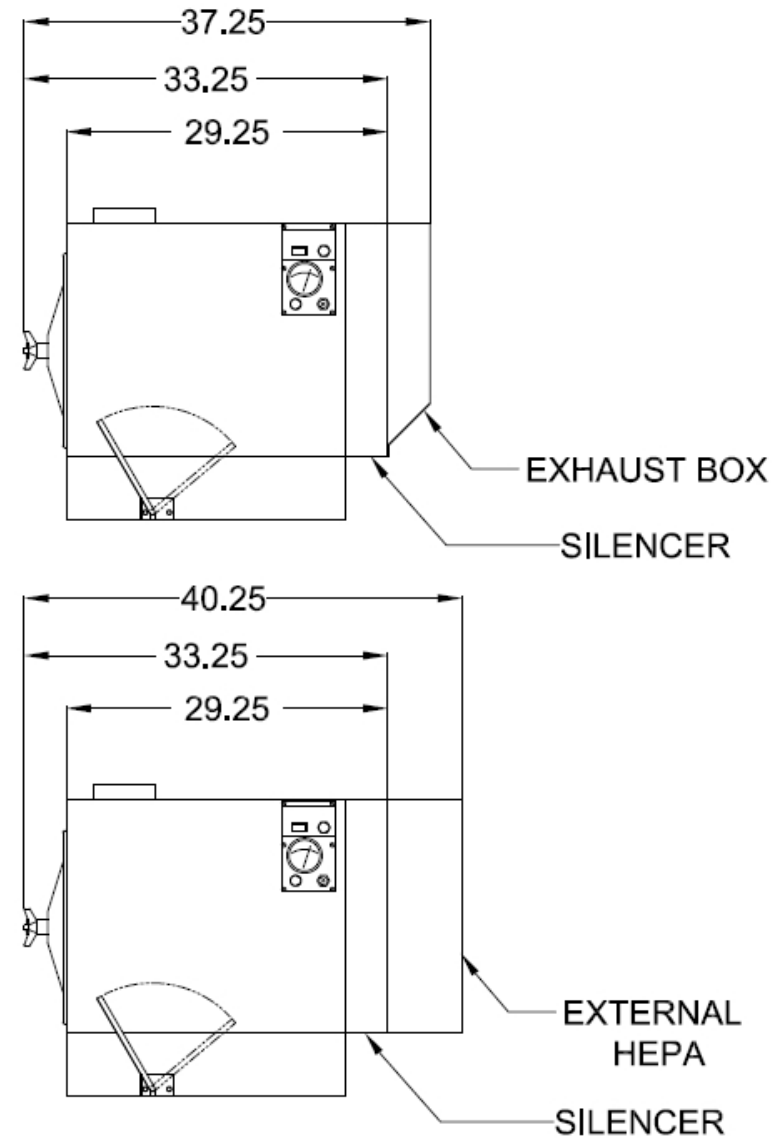
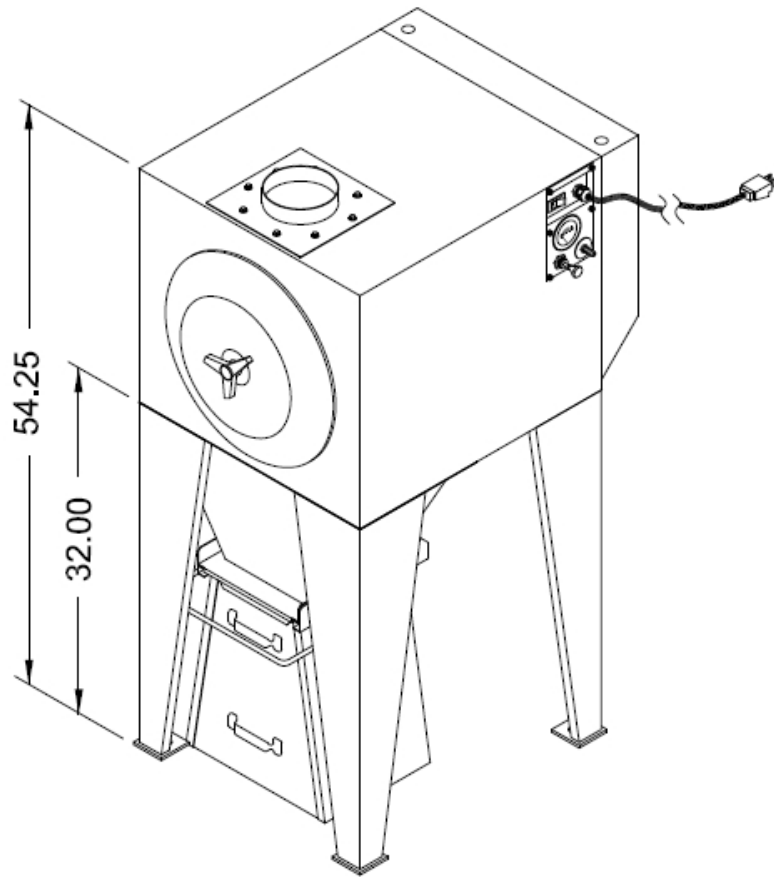

MODELS & OPTIONS:

Part #	Description
Main System / Part	
<input type="checkbox"/> DCH-1	Cartridge collector with 1 Clean 2® cartridge filter with 150 ft ² media, manual Vibra-Pulse® cleaning system 1HP 115/230/1/60 TEFC motor at 12/6 amps, 6" collar on top. Includes removable external dust tray.
<input type="checkbox"/> DCH-1-H10	Cartridge collector with (1) CLEAN-2 cartridge filter (150 sq. ft. of media), manual VIBRA-PULSE filter cleaning system, a 1 HP TEFC motor, 115/230/1/60Hz (12/6 amps), 6" dia. inlet collar on top, hopper with stand, and 10 gallon dust container.
Fan / Motor Upgrades or Options (when ordering main unit)	
<input type="checkbox"/> DCH-1-3 PHASE	1.5 Hp, TEFC motor 208-230-460/575/3/60 Hz Option for Standard DCH-1 Unit
<input type="checkbox"/> DCH-1-HP-1	1.5 Hp TEFC motor, 115/230/1/60 Hz, High Pressure Option for Standard DCH-1 Unit
<input type="checkbox"/> DCH-1-HP-3	1.5 Hp TEFC motor, 208-230/460/575/3/60 Hz, High Pressure Option for Standard DCH-1 Unit
Filter Options (when ordering main unit)	
<input type="checkbox"/> DCH-1-AD	Internal AD Option for Standard DCH-1 Unit. Order Charcoal separately.
<input type="checkbox"/> DCH-1-EXAD	External Adsorber Module Option for Standard DCH-1 Unit. Order Charcoal separately.
<input type="checkbox"/> DCH-1-EXDOP	External 95% DOP Filter Option for Standard DCH-1 Unit
<input type="checkbox"/> DCH-1-EXHE	External 99.97% HEPA Filter Option for Standard DCH-1 Unit
<input type="checkbox"/> DCH-1-FD	Fiber dust Filters Option for Standard DCH-1 Unit
<input type="checkbox"/> DCH-1-UCP	ULTRACLEAN-PLUS Cartridge Filters Option for Standard DCH-1 Unit
Preventative Maintenance Pressure Gauges, etc. (when ordering main unit)	
<input type="checkbox"/> DCH-1-PG-10	0-10" magna-helic pressure gauge, approximately 5" diameter size. Surface mounted.
Misc. Options	
<input type="checkbox"/> DCH-1-CASTERS	8" Fixed-front, 5" Swivel-rear Casters Option for Standard DCH-1 Unit
<input type="checkbox"/> DCH-1-CASTERS W/H10	Adds (2) 2.5" Swivel Casters & (2) 2.5" Fixed Casters Option for Standard DCH-1 Unit
<input type="checkbox"/> DCH-2-HYD-045	Hydro-filter designed to help eliminate sparks. C/w 45 gallon drum, easy to remove lid, water level gauge, and all required ductwork
<input type="checkbox"/> OM-019/160	Standing Flange for mounting Flexi-I Arms on DCH/PCH units
<input type="checkbox"/> DCH-1-EXPVENT	Explosion Vent door for single cartridge collectors. (PCH-1, ALH-1, DCH-1, DTH-1, DS-1 & Mini-Pac.
Sound Attenuation	
<input type="checkbox"/> DCH-1-S-EXT	External Silencer Option for Standard DCH-1 Unit
Fan, Light & Other Electrical Accessories	
<input type="checkbox"/> DCH-1-AP-1	Off line Auto Pulse, 1 Phase Option for Standard DCH-1 Unit
<input type="checkbox"/> DCH-1-AP-3	Off line Auto Pulse, 3 Phase Option for Standard DCH-1 Unit
<input type="checkbox"/> JSPH-154421-00	Manual Starter inside a NEMA 12 Enclosure with a Rotary knob on the front to turn the DCH-1 On & Off
Retro-Fit Parts	
<input type="checkbox"/> 2KT51733	External HEPA Retrofit Kit for PCH-1, PCH-2, DCH-1, DCH-2, DTH-800, DTH-1700
<input type="checkbox"/> 2KT51734	External AD Retrofit Kit for PCH-1, PCH-2, DCH-1, DCH-2, DTH-800, DTH-1700. Charcoal not included. Please order charcoal separately.
<input type="checkbox"/> 2KT51739	External HEPA & AD Retrofit Kit for PCH-1, PCH-2, DCH-1, DCH-2, DTH-800, DTH-1700. Charcoal not included. Please order charcoal separately.
<input type="checkbox"/> 2KT51768	External Silencer Retrofit Kit for PCH-1, PCH-2, DCH-1, DCH-2, DTH-800, DTH-1700

03-01

CUSTOMER:
 CUSTOMER P.O.:
 PROJECT:
 ENGINEER:
 SALES REP.:
 IDENTIFICATION / TAGGING:

> www.lev-co.com • 1.888.862.5356

lev-co

The device depicted and described hereon embodies proprietary information owned by the manufacturer. All design, manufacturing, reproduction, sales and patent rights regarding this device or drawing reserved except where explicit right is guaranteed in writing. We reserve the right to make design changes.

Drawn by: Janos-B
 Date: 3/31/2011
 Scale: NTS
 Weight: N/A

03-01 DCH-1
c/w External Tray or Hopper
Specification Drawing

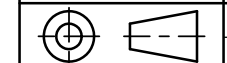

Drawing No.: -
 Material: -
 File Name: (03-01) DCH-1 - SD
 Sheet: 2/2