

TOP VIEW

(WITH OPT. HEPA/AD OUTLET SHOWN)

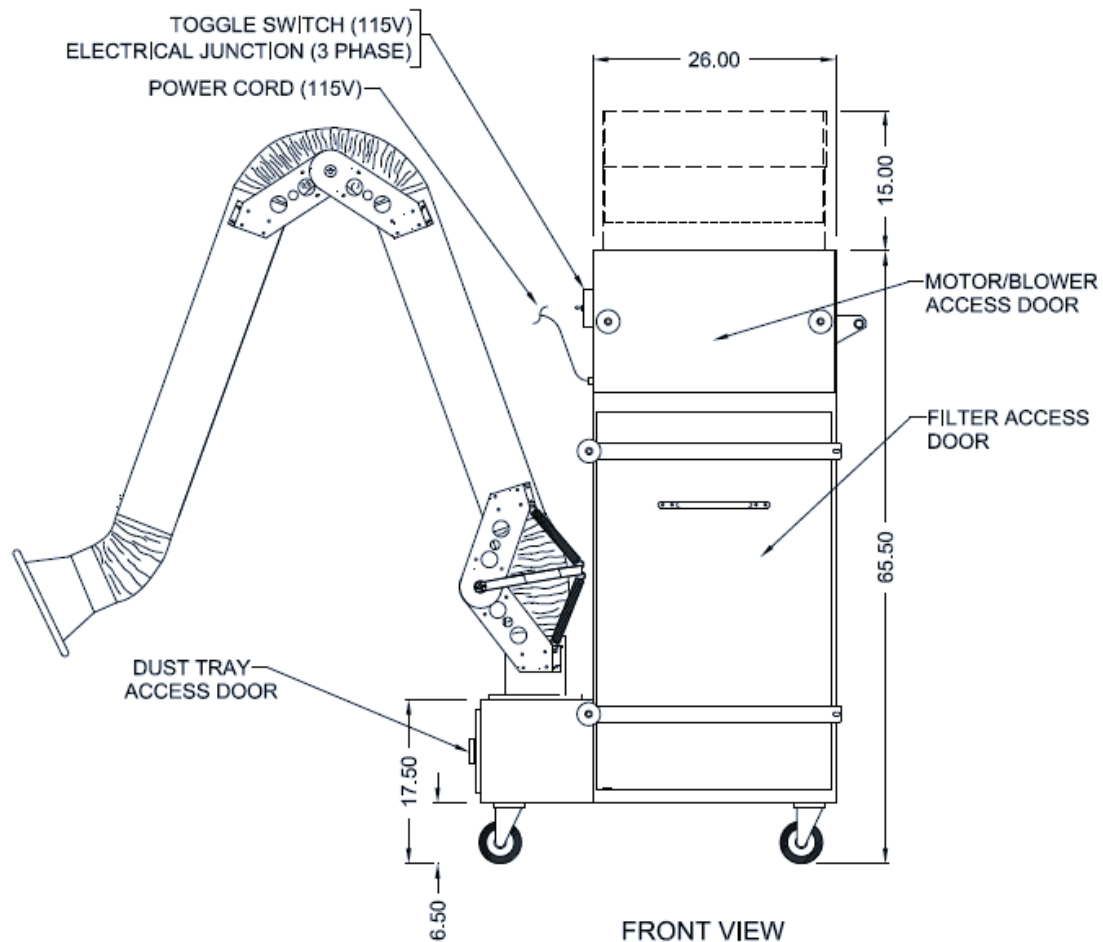

FRONT VIEW

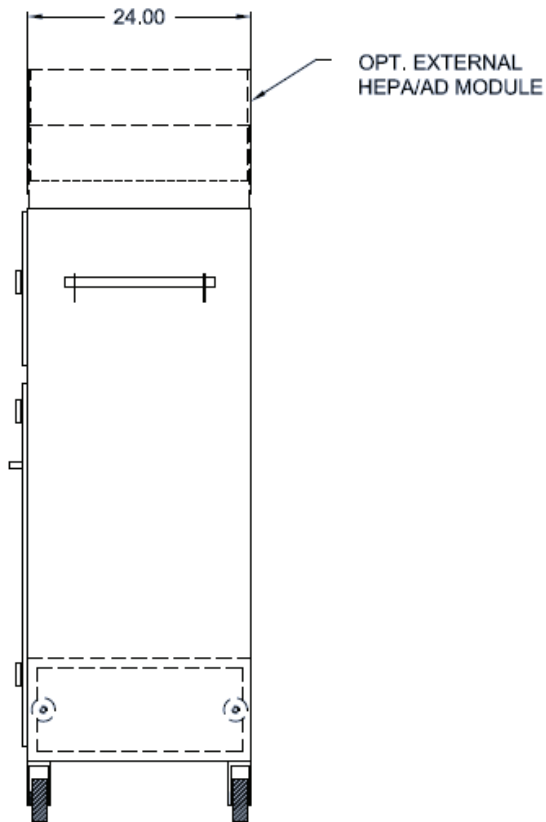

SIDE VIEW

**CONSTRUCTION:**

16 gauge all welded steel cabinet, finished with a Powder-Coat finish. Includes Ultra-Seal filter mounting system, side access door to filters and direct drive motor/blower, 10' E-Z ARM High Flow Extractor arm, 5" casters, power cord, and on-off switch (115V units). Three phase units wired to electrical junction box. (Circuit and motor overload protection by others.)

**WEIGHT:**

369 lbs.

**AIRFLOW:**

1000 CFM, 1.5 HP, std.  
1100 CFM, 2 / 3 HP, opt.  
900 CFM, HEPA, 2 / 3 HP, opt.

**ELECTRICAL:**

- 1.5 HP, 115/208-230/1/60, 17.0/8.5 amps, std.
- 1.5 HP 208-230/460/3/60/50, 4.9-4.6/2.3 amps, opt.
- 2 HP 208-230/460/575/3/60, 5.7-5.4/2.7 amps, opt.
- HP-3 HP 208-230/460/575/3/60, 8.0/4.0 amps, opt.

**NOISE:**

78 dBA , 68 dBA w/ silencer.

**FILTER SEAL:**

Ultra-Seal filter sealing locking mechanism for all main filters, optional HEPA filters and/or adsorber modules (when used). Slide in tracks shall be used for prefilters only

**FIRE SUPPRESSION:**

Equipment provided by others.

**SPECIFICATIONS:**

**PREFILTERS:**

- (1) 2" aluminum mesh, std.
- (1) Chevron mist eliminator, opt.

**MAIN FILTERS:**

- (1) 88 ft high pressure bag, 95%, std.
- (1) 65% short bag, opt.
- (1) Easy clean, opt.
- (1) Short bag followed by 95% D.O.P. (Int.), opt.
- (1) Shaker bag, opt.

**HEPA OPTION:**

- (1) External HEPA, 99.97%, opt.
- (1) Short bag followed by 99.97% HEPA (Int.), opt.

**AD OPTION:**

- Std. prefilter followed by 36 ft , 95% short bag filter, followed by (2) 25 lb. refillable v-bank carbon modules, followed by a 2" pleat afterfilter

**OTHER OPTIONS:**

- Pressure gauge kit indicates filter changes
- 14' E-Z ARM High Flow Extractor
- Dual 10' E-Z ARM High Flow Extractors

FILTER EFFICIENCIES BASED ON ASHRAE 52-76 TEST METHOD  
ALL FLOWS STANDARD AIR AND FILTERS UNLESS OTHERWISE INDICATED.

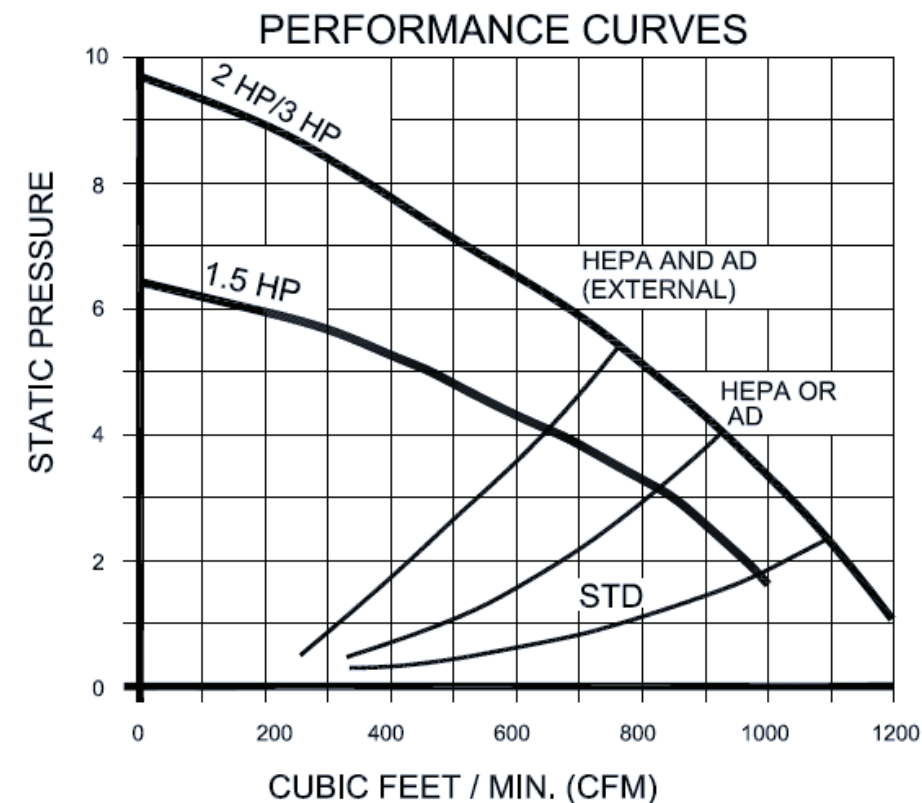

02-06

CUSTOMER:	
CUSTOMER P.O.:	
PROJECT:	
ENGINEER:	
SALES REP.:	
IDENTIFICATION / TAGGING:	

> [www.lev-co.com](http://www.lev-co.com) • 1.888.862.5356



The device depicted and described hereon embodies proprietary information owned by the manufacturer. All design, manufacturing, reproduction, sales and patent rights regarding this device or drawing reserved except where explicit right is guaranteed in writing. We reserve the right to make design changes.

Drawn by:	Janos B
Date:	7/14/2009
Scale:	NTS
Weight:	N/A

02-06 PORTABLE DUST COLLECTOR PAC91	
Specification Drawing	
Drawing No.:	-
Material:	-
File Name:	(02-06) PAC91 - SD
Sheet:	1/2

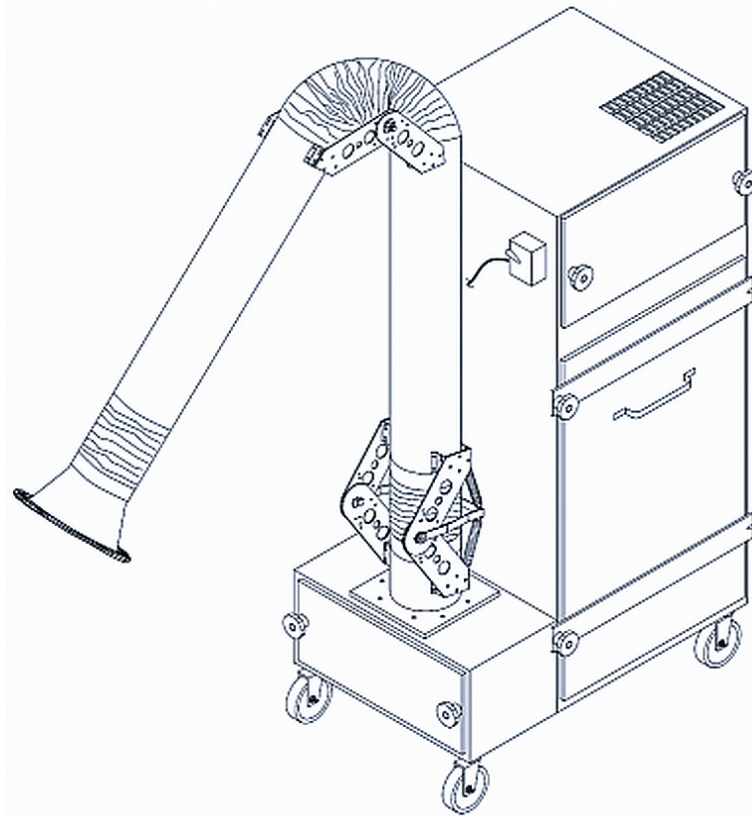

STD WITH 7E10  
E-Z ARM

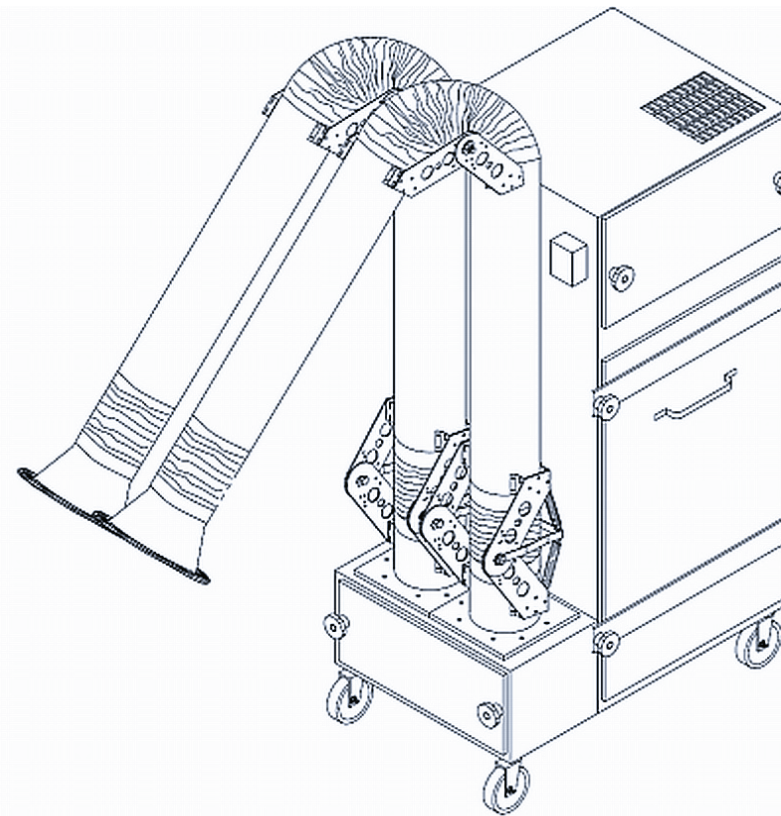

OPTIONAL DUAL  
ARM UNIT

**MODELS & OPTIONS:**

Part #	Description
<b>Main System / Part</b>	
<input type="checkbox"/> PAC91	Portable air cleaner, includes 10' E-Z ARM® arm, 2" mesh prefilter, 95% polyester high pressure bag filter, 88ft <sup>2</sup> , 1 HP TEFC motor, 115/230/1 Hz, 17.0/8.5 amps on-off switch, and power cord (on 115v only), 5" casters.
<input type="checkbox"/> PAC91-DA	Portable air cleaner, includes Dual 10' E-Z ARM® arms, 2" mesh prefilter, 95% polyester high pressure bag filter, 88ft <sup>2</sup> , 1 HP TEFC motor, 115/230/1 Hz, 17.0/8.5 amps on-off switch, and power cord (on 115v only), 5" casters.
<b>Fan / Motor Upgrades or Options (when ordering main unit)</b>	
<input type="checkbox"/> PAC91-3 PHASE	1.5Hp TEFC Motor, 20/230/460/575/3/60 Hz Std Option for Standard PAC91 Unit
<input type="checkbox"/> PAC91-3HP	3HP TEFC Motor, 208-230/460/575/3/60Hz High Pressure Option for Standard PAC91 Unit
<b>Extraction Arms</b>	
<input type="checkbox"/> PAC91-7E14-DD	14' Long E-Z Arm High Flow Extractor Option for Standard PAC91 Unit
<input type="checkbox"/> PAC91-7E10-DD	7' Long E-Z Arm High Flow Extractor Option in place of standard 10' Long E-Z Arm for PAC91 Unit.
<b>Filter Options (when ordering main unit)</b>	
<input type="checkbox"/> PAC91-65%	65% bag filter in place of standard 95% bag.
<input type="checkbox"/> PAC91-95DOP	Internal 95% DOP Filter Option for Standard PAC91 Unit
<input type="checkbox"/> PAC91-AD	Internal AD Module Option for Standard PAC91 Unit
<input type="checkbox"/> PAC91-EC	Easy Clean Bag Filter Option for Standard PAC91 Unit
<input type="checkbox"/> PAC91-EXAD	External AD Modules Filter Option for Standard PAC91 Unit
<input type="checkbox"/> PAC91-HEPA	Short bag and 99.97% HEPA (internal).
<input type="checkbox"/> PAC91-EXDOP	External 95% DOP Filter Option for Standard PAC91 Unit
<input type="checkbox"/> PAC91-EXHE	External 99.97% HEPA Filter Option for Standard PAC91 Unit
<b>Preventative Maintenance Pressure Gauges, etc. (when ordering main unit)</b>	
<input type="checkbox"/> PAC91-PG-6	0-6" magnahelic pressure gauge, approximately 5" diameter size. Surface mounted.
<b>Sound Attenuation</b>	
<input type="checkbox"/> PAC91-S	Acoustic Lining of Blower Cabinet Option for Standard PAC91 Unit
<input type="checkbox"/> PAC91-S-EXT	Exhaust Silencer Option for Standard PAC91 Unit
<b>Misc. Options (when ordering main unit)</b>	
<input type="checkbox"/> PAC91-3HP-EXP PROOF	3HP - 575/3/60 Explosion Proof Motor Option for PAC-91

02-06

CUSTOMER:  
CUSTOMER P.O.:  
PROJECT:  
ENGINEER:  
SALES REP.:  
IDENTIFICATION / TAGGING:

> [www.lev-co.com](http://www.lev-co.com) • 1.888.862.5356

**lev-co**

The device depicted and described hereon embodies proprietary information owned by the manufacturer. All design, manufacturing, reproduction, sales and patent rights regarding this device or drawing reserved except where explicit right is guaranteed in writing. We reserve the right to make design changes.

Drawn by: Janos B  
Date: 7/14/2009  
Scale: NTS  
Weight: N/A

02-06 PORTABLE DUST COLLECTOR  
PAC91  
Specification Drawing

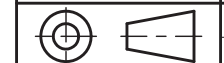

Drawing No.: -  
Material: -  
File Name: (02-06) PAC91 - SD  
Sheet: 2/2